



ZET6223

Product Specification

[Doc.No: ZP-HW-PS-0007 Doc. Type: Product Specification. Revision Number: 1.0]

NOTICE TO PERSONS RECEIVING THIS
DRAWING AND/OR TECHNICAL INFORMATION

ZEITEC Semiconductor Co., LTD. reserves the right to make changes without further notice to the materials described herein. ZEITEC does not assume any liability arising out of the application or use of any product or circuit described herein. ZEITEC does not authorize its products for use as critical components in life-support systems where a malfunction or failure may reasonably be expected to result in significant injury to the user. The inclusion of ZEITEC product in a life-support systems application implies that the manufacturer assumes all risk of such use and in doing so indemnifies ZEITEC against all charges.

	Title	ZET6223 Product Specification	Date Originated: 29-Jun-12
			Revision: 1.0
ZEITEC Semiconductor	Doc #:	ZP-HW-PS-0007	Date Revised: 1-Oct-12

IDENTIFICATION

Document Title **ZET6221 Preliminary Product Specification**

Document Number ZP-HW-PS-0007

Version Version 1.0

Date 1-Oct-12

APPROVALS

Authority	Name	Date
Author	Alex	9-May-12

HISTORY

Version	Date	Purpose	Pages
0.1	9-May-12	Preliminary version	All
1.0	1-Oct-12	Update QFN48 Package	All

	Title	ZET6223 Product Specification	Date Originated: 29-Jun-12
			Revision: 1.0
ZEITEC Semiconductor	Doc #: ZP-HW-PS-0007		Date Revised: 1-Oct-12

48-ch, touch panel controller

ZET6223 is a single chip solution for capacitive touch panel applications. You can use one ZET6223 to implement touch panel measuring up to 11.6-inch diagonally. It comprises a high performance capacitive-to-digital analog front end, x51 based MCU, and embedded 64K flash memory. The touch solution supports SPI, I2C and GPIO interfaces for most of the devices as MID, Tablet, NB, Ultrabook, e-book, PND, POS etc.

- **System operating voltage :**
2.6V ~ 3.6V
- **System operating temperature :**
-20 °C ~ 85 °C
- **48 touch sense channels :**
Standard type : Up to 11.6"
- **Flexible capacitive sense method :**
Mutual-Capacitive-Sensing
- **Minimize current consumption :**
 - Active Operation Mode:
Touch : 10mA (Typ.)
Non-Touch : 1mA (Typ.)
 - Idle Mode : 240uA (Typ.)
 - Sleep Mode is less than 35uA (Typ.)
- **True 10 fingers Multi-Touch supported**
- **High Signal to Noise Ratio > 100**
 - Maximum 18 driving traces with programmable High Voltage,
- **Fast touch response time :**
 - Up to 120Hz/frame for single touch ,
 - 80Hz/frame for 5 touches,
 - 60Hz/frame for 10 touches.
- **Easy to program touch panel characters by Zeki App.**
- **Up to 6mm cover lens thickness.**
- **Environment variation insensitive**
 - Temperature Drift Compensation
 - LCM/RFI Noise Immunity
 - Touch Trace Variation Insensitive RC < 1e-5
 - Charger Noise Immunity
- **Interface supported :**
1.8V/3.3V Inter-IC Interface (I2C)
Serial Peripheral Interface (SPI)
- **Glove or Stylus supported**
- **Chip-On Board supported**
- **Internal power-on reset and external reset control**
- **Electrostatic discharge noise :**
Human Body Mode ≥ ±2KV
Machine Mode ≥ ±200V
Latch up ≥ ±200mA, +2V
- **Package features:**
ZET6223WTA QFN68
ZET6223WNA QFN48

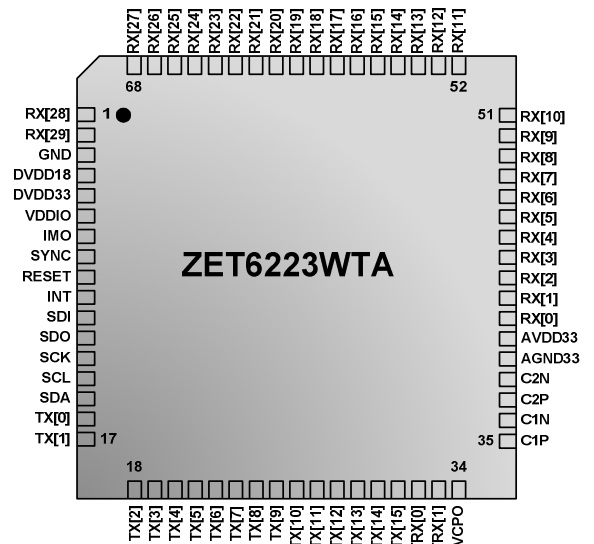

	Title ZET6223 Product Specification	Date Originated: 29-Jun-12
		Revision: 1.0
ZEITEC Semiconductor	Doc #: ZP-HW-PS-0007	Date Revised: 1-Oct-12

The ZEITEC IC is designed to detect finger touch on up to max 48 traces when used with a scanned, mutual mode. ZET6223 can be applied to almost any kind of materials, e.g. glass, plastic, and even air gap cardboard, up to thicknesses of 6 mm or more. The touch areas are defined as 2-part integrated conductive material, like copper or screened silver or carbon deposited on the rear of a covered panel. Panel shapes, sizes and placement are almost arbitrary. The sensitivity of each panel can be configured individually via simple command over the I2C port by our touch panel develop kit, Zeki. All Key parameters are stored and downloaded to main ROM as new parameter.

The ZET6223 is designed for appliances such as electronic control, control panels, personal instruments, or similar products, whose touch panels that need to be immunity to temperature, humidity, dirt accumulation, or the physical deterioration of the panel surface from abrasion, chemicals, or abuse. For this purpose, ZET6223 implemented environmental detection and self-calibration, temperature compensation and noise filtering algorithms that make the sensing functions robust. The ZET6223 features continuous self-diagnosis and reporting status, to allow its use in critical consumer appliance applications, even for application debug.

General PCB or FPC materials can be used as the circuit substrate; the overlying panel can be made of any insulation material. External circuitry consists of only a few passive components. Touch control and data transfer is via I2C port. Devices using ZEITEC advanced sensing technologies can achieve high sensitivity and high noise immunity performance.

The Touch Panel Module is a capacitive-type which customers use to conform to flat panel display. Once user's finger touches Touch Panel Module, this Touch Panel Module will response the coordinates of points that user touches and finger number.



	Title	ZET6223 Product Specification	Date Originated: 29-Jun-12
			Revision: 1.0
ZEITEC Semiconductor	Doc #: ZP-HW-PS-0007		Date Revised: 1-Oct-12

Table of Contents

1	PRODUCT OVERVIEW	1
1.1	General Description	1
1.2	Easy to Design-in	1
2	PRODUCT INFORMATION	3
2.1	Package Type	3
2.2	Pin Descriptions	5
2.3	Features Selection Table	9
2.4	Hardware Architecture	10
2.4.1	Schematic Description	10
2.4.2	I/O Voltage Selection	10
3	TOUCH SCREEN LAYOUT	12
3.1	Resolution / DPI / Trace Number	12
3.2	ITO Sensor Cell	13
3.2.1	Design Rule	13
3.2.2	Design Consideration	14
3.3	Touch Screen Design example	15
3.3.1	10.1" 48ch (TX : RX = 18 : 30) Touch Solution	15
4	INTERFACE AND COMMUNICATION TIMING	17
4.1	Pin Description	17
4.2	I2C Slave Mode	17
4.3	I2C Slave Mode Communication Address	18
4.4	I2C Slave Mode Communication Dynamic Format	18
4.4.1	Dynamic Coordinate TX Normal Packet (Touch Panel to Host)	28
4.4.2	Reference C Program	34
4.5	TP Command	34
4.5.1	Reference C Program	36
4.6	Boot Loader Workflow	40
4.6.1	Reference C Program	40
5	AC CHARACTERISITIC	44
5.1	I2C Slave Mode Communication Timing	44
5.2	RC and Reset Timing	45
6	DC CHARACTERISTICS	46
6.1	Absolute Maximum Ratings	47
6.2	DC Electrical Characteristics	48
7	PACKAGE INFORMATION	49
7.1	68Pin, QFN 8mm X 8mm	49
7.2	48Pin, QFN 6mm X 6mm	50
8	MARKING DEFINITION	51
8.1	Marking Information	51

	Title	ZET6223 Product Specification	Date Originated: 29-Jun-12
			Revision: 1.0
ZEITEC Semiconductor	Doc #: ZP-HW-PS-0007	Date Revised: 1-Oct-12	

List of Figures

Figure 1-1 ZEITEC FPC Bom	1
Figure 1-2 Touch Sensor	1
Figure 1-3 Zeki	1
Figure 1-4 Zeki Connects to Touch Panel.....	1
Figure 1-5 Sensitivity Settings in Zeki GUI	2
Figure 2-1 Pin Assignment.....	3
Figure 2-2 Zet6223 QFN68 Schematic Reference.....	10
Figure 2-3 the Reference Schematic of Separated Power Supply	11
Figure 2-4 the Reference Schematic of Single VCC Power	11
Figure 3-1 Touch Screen Outline Dimension.....	12
Figure 3-2 ITO Cell Paramenter Define	13
Figure 3-3 10.1" 48ch (TX : RX = 18 : 30) Touch Screen ,Origin at (X0,Y0)	15
Figure 4-1 I2C Pin Define	17
Figure 4-2 Connection between Touch Panel and Host in I2C Slave Mode	18
Figure 4-3 Packet – Byte 1 ~ Byte 2	20
Figure 4-4 Packet – Byte 3 ~ Byte 5	20
Figure 4-5 Packet – Byte 6 ~ Byte 8	21
Figure 4-6 Packet – Byte 9 ~ Byte 11	21
Figure 4-7 Packet – Byte 12 ~ Byte 14	22
Figure 4-8 Packet – Byte 15 ~ Byte 17	22
Figure 4-9 Packet – Byte 18 ~ Byte 20	23
Figure 4-10 Packet – Byte 21 ~ Byte 23.....	23
Figure 4-11 Packet – Byte 24 ~ Byte 26.....	24
Figure 4-12 Packet – Byte 27 ~ Byte 29.....	24
Figure 4-13 Packet – Byte 30 ~ Byte 32.....	25
Figure 4-14 Packet – Byte 33 ~ Byte 35.....	25
Figure 4-15 Packet – Byte 36 ~ Byte 38.....	26
Figure 4-16 Packet – Byte 39 ~ Byte 41.....	26
Figure 4-17 Packet – Byte 42 ~ Byte 44.....	27
Figure 4-18 Boot Loader Flow	40
Figure 5-1 I2C Interface Timing	44
Figure 5-2 IRC Power-on Initialization Timing	45
Figure 6-1 Valid Operating Region	46
Figure 7-1 68-Pin, QFN 8mm X 8mm	49
Figure 7-2 48Pin, QFN 6mm X 6mm	50
Figure 8-1 Ordering Code Definitions	51

	Title ZET6223 Product Specification	Date Originated: 29-Jun-12
		Revision: 1.0
ZEITEC Semiconductor	Doc #: ZP-HW-PS-0007	Date Revised: 1-Oct-12

List of Tables

Table 2-1 Pin Descriptions	5
Table 2-2 Feature Selection Table	9
Table 3-1 Touch Screen Outline Define	12
Table 3-2 Touch Panel for ZET6223 Design Table	16
Table 4-1 Pin Description	17
Table 4-2 I2C Address	18
Table 4-3 24 Bytes Data Format (Five Fingers + Key Application).....	28
Table 4-4 Byte2 and Byte3	29
Table 4-5 MSB 4 Bits of Byte4 and 8 Bits of Byte5.....	29
Table 4-6 LSB 4 Bits of Byte4 and 8 Bits of Byte6.....	29
Table 4-7 MSB 4 Bits of Byte8 and 8 Bits of Byte9.....	30
Table 4-8 LSB 4 bits of Byte8 and 8 Bits of Byte10	30
Table 4-9 MSB 4 Bits of Byte12 and 8 Bits of Byte13	30
Table 4-10 LSB 4 Bits of Byte12 and 8 Bits of Byte14	30
Table 4-11 MSB 4 Bits of Byte16 and 8 Bits of Byte17	30
Table 4-12 LSB 4 Bits of Byte16 and 8 Bits of Byte18	31
Table 4-13 MSB 4 Bits of Byte20 and 8 Bits of Byte21	31
Table 4-14 LSB 4 Bits of Byte20 and 8 Bits of Byte22	31
Table 4-15 MSB 4 Bits of Byte24 and 8 Bits of Byte25	31
Table 4-16 LSB 4 Bits of Byte24 and 8 Bits of Byte26	31
Table 4-17 MSB 4 Bits of Byte28 and 8 Bits of Byte29	32
Table 4-18 LSB 4 Bits of Byte28 and 8 Bits of Byte30	32
Table 4-19 MSB 4 Bits of Byte32 and 8 Bits of Byte33	32
Table 4-20 LSB 4 Bits of Byte32 and 8 Bits of Byte34	32
Table 4-21 MSB 4 Bits of Byte36 and 8 Bits of Byte37	33
Table 4-22 LSB 4 Bits of Byte36 and 8 Bits of Byte38	33
Table 4-23 MSB 4 Bits of Byte40 and 8 Bits of Byte41	33
Table 4-24 LSB 4 Bits of Byte40 and 8 Bits of Byte42	33
Table 4-25 Byte 44 of TX Data	33
Table 4-26 Byte 7/11/15/19/23/27/31/35/39/43 of TX Data	34
Table 4-27 Supported TP Command Type	34
Table 5-1 Characteristics of the SDA and SCL Pins for I2C Interface	44
Table 5-2 IRC and Reset Timing	45
Table 6-1 Unit of Measure	46
Table 6-2 Absolute Maximum Ratings	47
Table 6-3 DC Specifications	48
Table 8-1 Ordering Information.....	51

	Title	ZET6223 Product Specification	Date Originated: 29-Jun-12
			Revision: 1.0
ZEITEC Semiconductor	Doc #: ZP-HW-PS-0007		Date Revised: 1-Oct-12

1 PRODUCT OVERVIEW

1.1 General Description

ZET6223 is a single chip solution for projected capacitive touch panel and touch pad applications. It includes all signal processing functions to provide stable sensing under a wide variety of changing conditions. Only a few external components are required in BOM.

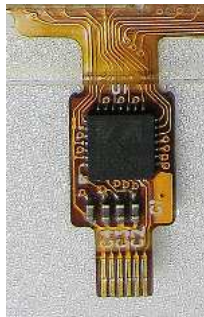

Figure 1-1 ZEITEC FPC Bom

The entire circuit can be built within a few square centimetres of single-sided FPC or PCB area (Figure 1-1).

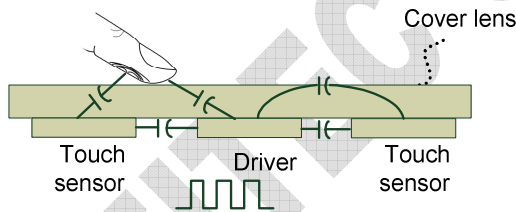

Figure 1-2 Touch Sensor

ZET6223 employs advance touch sensing, a technology that senses changes in electrical charge forced across an electrode by a pulse edge. The devices use I²C interface to allow parameter data to be extracted and to permit individual touch panel parameter setup. The interface protocol uses simple single byte commands and responds with single byte responses in most cases. The command structure is designed to minimize the amount of data traffic

while maximizing the amount of information conveyed.

In addition to normal operating and setup functions, ZET6223 can also report back actual signal strengths and error codes. Zeki software for the PC can be used to program the operation of the IC as well as read back touch sensor status and signal levels in real time.

1.2 Easy to Design-in

Zeki is designed for fine-tune firmware algorithm to fit various ITO characteristics in an easy and fast way to shorten design-in period.

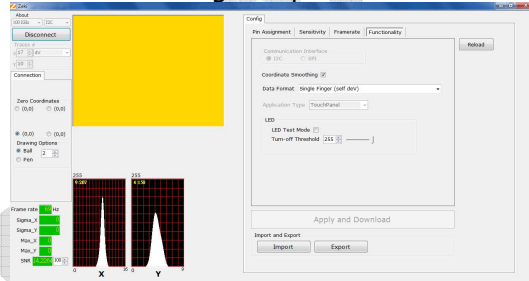

Figure 1-3 zeki

Configuration is very easy to change for ZET6223 series by using "Zeki" (Figure 1-3). Zeki provides a friendly and straight forward GUI to help users configure sensor trace numbers, defined parameters and can generate application setting code which can be reloaded to ZET6223 series IC.

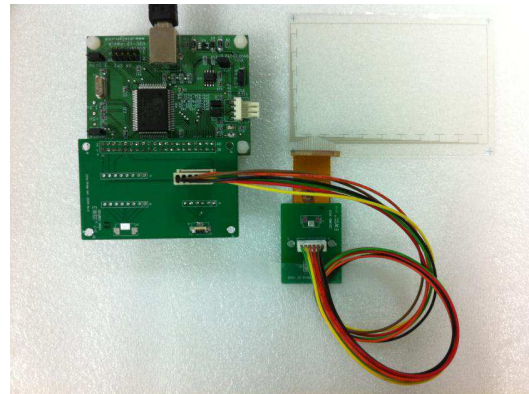



Figure 1-4 Zeki Connects to Touch Panel

	Title	ZET6223 Product Specification	Date Originated: 29-Jun-12 Revision: 1.0
	ZEITEC Semiconductor	Doc #: ZP-HW-PS-0007	Date Revised: 1-Oct-12

Connecting Zeki hardware demo board or customer FPC with Zeki is shown as (Figure 1-4), sensor sensitivity, threshold, frame rate, touch run time status can be adjusted at any time (Figure 1-5).

immediately show the result which is running by new settings. Customers can see what they configured immediately and to change settings back and forth until all functionalities works perfect. Finally, Zeki will save all parameters and reload to ZET6223 chip. A design of Touch product is completed, quickly and easily.

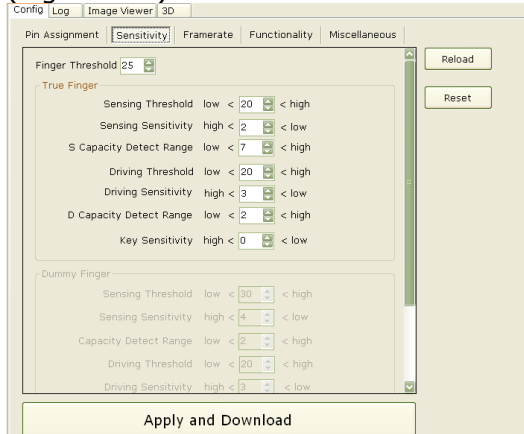



Figure 1-5 Sensitivity Settings in Zeki GUI

After completion of parameters setting such as sensitivity, framerate and other advanced options. Connecting to touch panel, Zeki can

ZEITEC Confidential

	Title	ZET6223 Product Specification	Date Originated: 29-Jun-12
			Revision: 1.0
ZEITEC Semiconductor	Doc #:	ZP-HW-PS-0007	Date Revised: 1-Oct-12

2 PRODUCT INFORMATION

2.1 Package Type

ZET6223 is provided with the package QFN68/QFN48 for 3.5"~11.6" touch panel, and pin assignment is shown below.

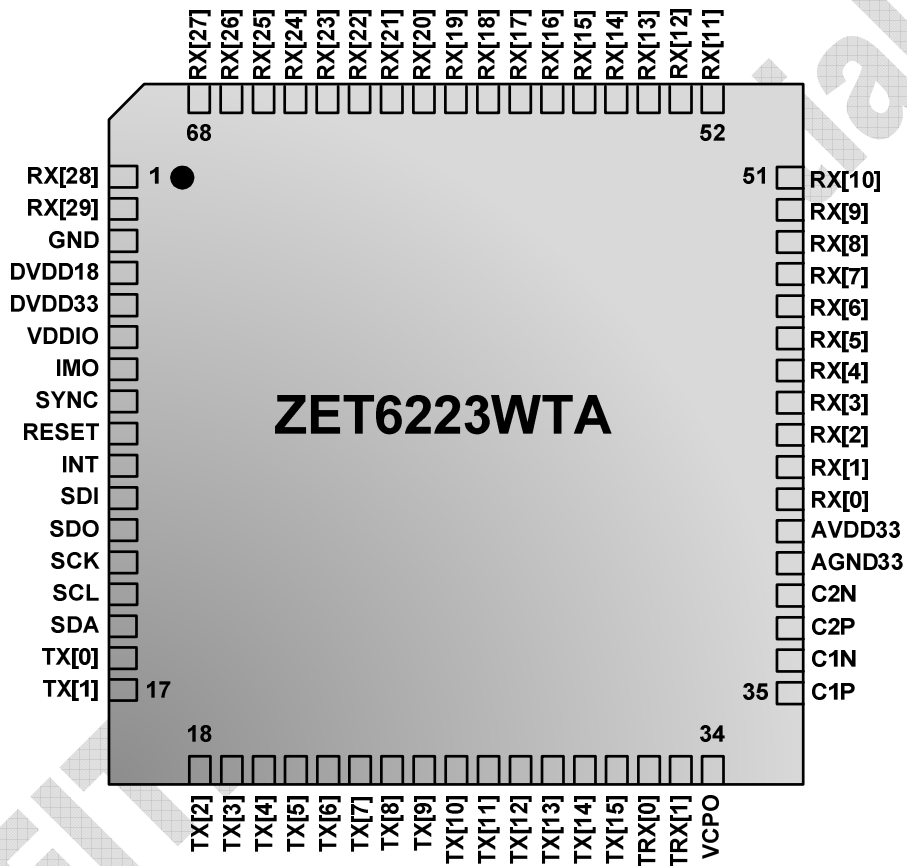

QFN68, ZET6223WTA, 8x8 mm

Figure 2-1 Pin Assignment

	Title	ZET6223 Product Specification	Date Originated: 29-Jun-12
			Revision: 1.0
ZEITEC Semiconductor	Doc #:	ZP-HW-PS-0007	Date Revised: 1-Oct-12

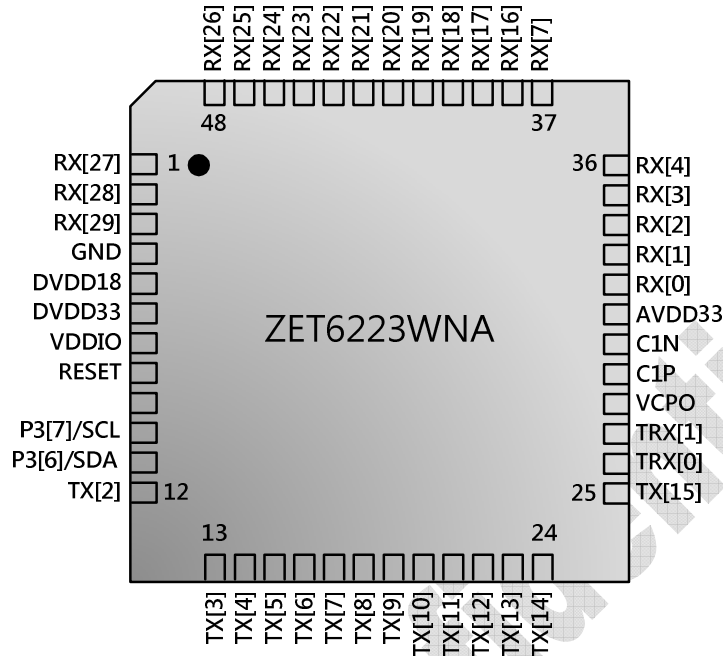

QFN48, ZET6223WNA, 6x6 mm

Figure 2-2 Pin Assignment

	Title	ZET6223 Product Specification	Date Originated: 29-Jun-12
			Revision: 1.0
ZEITEC Semiconductor	Doc #: ZP-HW-PS-0007	Date Revised: 1-Oct-12	

2.2 Pin Descriptions

Table 2-1 Pin Descriptions

QFN PIN No	Symbol	Type	Description	
68	48			
1	2	RX[28]	I/P	Receiver input pin No. 28
2	3	RX[29]	I/P	Receiver input pin No. 29
3	4	GND	GND	Digital ground
4	5	DVDD18	PWR	Digital 1.8V Power Supply : Digital 1.8V power supply, generated by internal regulator. A 1uF ceramic capacitor to GND is required.
5	6	DVDD33	PWR	Digital 3.3V Power Supply : Digital 3.3V power supply. A 1uF ceramic capacitor to GND is required.
6	7	VDDIO	PWR	Digital I/O Power Supply : Determined by directly connecting to DVDD18 or DVDD33 with 1.8V or 3.3V interface I2C/SPI communication.
7		IMO	I/O	Main clock input/output pin : System clock input or output pin.
8		SYNC	I/O	Synchronization Signal I/O for cascade multichip structure
9	8	RESET	I/P	External Reset : RESET = 1, reset function is dis-activated. RESET = 0, reset function is activated. An internal $15K\Omega \pm 30\%$ resistor is pulled high to DVDD33.
10	9	INT	O/P	External interrupt to the host.
11		SDI	I/P	Serial Data Input : For serial peripheral interface (SPI) mode.
12		SDO	O/P	Serial Data Output : For serial peripheral interface (SPI) mode.
13		SCK	I/O	Serial Clock : Serial clock input (slave device) and output (master device) in serial peripheral interface (SPI) mode.
14	10	SCL	I/O	SCL : For Inter-IC interface (I2C) mode. Clock input as slave device and output as master device. It needs the pull high resistor to VDDIO (Internal $4.7K\Omega \pm 20\%$ pull high resistor can be selected by Zeki).
15	11	SDA	I/O	SCL : For Inter-IC interface (I2C) mode. Data input and output. It needs the pull high resistor to VDDIO (Internal $4.7K\Omega \pm 20\%$ pull high resistor can be selected by Zeki).
16		TX[0]	O/P	Transmit output pin No. 0

	Title	ZET6223 Product Specification	Date Originated: 29-Jun-12
			Revision: 1.0
ZEITEC Semiconductor	Doc #: ZP-HW-PS-0007	Date Revised: 1-Oct-12	

17		TX[1]	O/P	Transmit output pin No. 1
18	12	TX[2]	O/P	Transmit output pin No. 2
19	13	TX[3]	O/P	Transmit output pin No. 3
20	14	TX[4]	O/P	Transmit output pin No. 4
21	15	TX[5]	O/P	Transmit output pin No. 5
22	16	TX[6]	O/P	Transmit output pin No. 6
23	17	TX[7]	O/P	Transmit output pin No. 7
24	18	TX[8]	O/P	Transmit output pin No. 8
25	19	TX[9]	O/P	Transmit output pin No. 9
26	20	TX[10]	O/P	Transmit output pin No. 10
27	21	TX[11]	O/P	Transmit output pin No. 11
28	22	TX[12]	O/P	Transmit output pin No. 12
29	23	TX[13]	O/P	Transmit output pin No. 13
30	24	TX[14]	O/P	Transmit output pin No. 14
31	25	TX[15]	O/P	Transmit output pin No. 15
32	26	TRX[0]	I/O	Programmable transmit output and receive input pin No. 0
33	27	TRX[1]	I/O	Programmable transmit output and receive input pin No. 1
34	28	VCPO	PWR	Internal generated voltage power supply for transmit output voltage. A 1uF ceramic capacitor to ground is required.
35	29	C1P	I/O	Charge pump capacitor. A 0.1uF capacitor to C1N is required for 10V transmit driving voltage.
36	30	C1N	I/O	Charge pump capacitor. A 0.1uF capacitor to C1P is required for 10V transmit driving voltage.
37		C2P	I/O	Charge pump capacitor. A 0.1uF capacitor to C2N is required for 10V transmit driving voltage.
38		C2N	I/O	Charge pump capacitor. A 0.1uF capacitor to C2P is required for 10V transmit driving voltage.

	Title	ZET6223 Product Specification	Date Originated: 29-Jun-12
			Revision: 1.0
ZEITEC Semiconductor	Doc #: ZP-HW-PS-0007	Date Revised: 1-Oct-12	

39		AGND33	GND	Analog ground.
40	31	AVDD33	PWR	Analog 3.3V power supply
41	32	RX[0]	I/P	Receiver input pin No. 0
42	33	RX[1]	I/P	Receiver input pin No. 1
43	34	RX[2]	I/P	Receiver input pin No. 2
44	35	RX[3]	I/P	Receiver input pin No. 3
45	36	RX[4]	I/P	Receiver input pin No. 4
46	37	RX[5]	I/P	Receiver input pin No. 5
47		RX[6]	I/P	Receiver input pin No. 6
48		RX[7]	I/P	Receiver input pin No. 7
49		RX[8]	I/P	Receiver input pin No. 8
50		RX[9]	I/P	Receiver input pin No. 9
51		RX[10]	I/P	Receiver input pin No. 10
52		RX[11]	I/P	Receiver input pin No. 11
53		RX[12]	I/P	Receiver input pin No. 12
54		RX[13]	I/P	Receiver input pin No. 13
55		RX[14]	I/P	Receiver input pin No. 14
56		RX[15]	I/P	Receiver input pin No. 15
57	38	RX[16]	I/P	Receiver input pin No. 16
58	39	RX[17]	I/P	Receiver input pin No. 17
59	40	RX[18]	I/P	Receiver input pin No. 18
60	41	RX[19]	I/P	Receiver input pin No. 19

	Title	ZET6223 Product Specification	Date Originated: 29-Jun-12
			Revision: 1.0
ZEITEC Semiconductor	Doc #:	ZP-HW-PS-0007	Date Revised: 1-Oct-12

61	42	RX[20]	I/P	Receiver input pin No. 20
62	43	RX[21]	I/P	Receiver input pin No. 21
63	44	RX[22]	I/P	Receiver input pin No. 22
64	45	RX[23]	I/P	Receiver input pin No. 23
65	46	RX[24]	I/P	Receiver input pin No. 24
66	47	RX[25]	I/P	Receiver input pin No. 25
67	48	RX[26]	I/P	Receiver input pin No. 26
68	1	RX[27]	I/P	Receiver input pin No. 27

I/P : Input port only
 O/P : Output port only
 I/O : Input and output
 PWR : Power
 GND : Ground

ZEITEC Confidential

	Title	ZET6223 Product Specification	Date Originated: 29-Jun-12
			Revision: 1.0
ZEITEC Semiconductor	Doc #: ZP-HW-PS-0007		Date Revised: 1-Oct-12

2.3 Features Selection Table

The following Table shows supported functionalities for different IC model.

Table 2-2 Feature Selection Table

Flash IC	PKG.	I2C	SPI	Reset	INT	Max Sensor NO.
ZET6223WTA	QFN68	1	1	1	1	48 (TX:TRX:RX=16:2:30)
ZET6223WNA	QFN48	1		1	1	36(TX:TRX:RX=14:2:20)

ZEITEC Confidential

	Title	ZET6223 Product Specification	Date Originated: 29-Jun-12 Revision: 1.0
	ZEITEC Semiconductor	Doc #: ZP-HW-PS-0007	Date Revised: 1-Oct-12

2.4 Hardware Architecture

2.4.1 Schematic Description

Figure 2-2 describes the Zet6223 IC reference circuit. It include the Power Pin (AVDD33 · AGND33 · DVDD33 · GND · VDDIO · DVDD18), I2C interface, transmit traces (TX[0]~TX[15]), receive traces (RX[0]~RX[29]) and user-defined traces (TRX[0]~TRX[1]) by channel design of touch panel. It also defines the external element and interface which needs for implement.

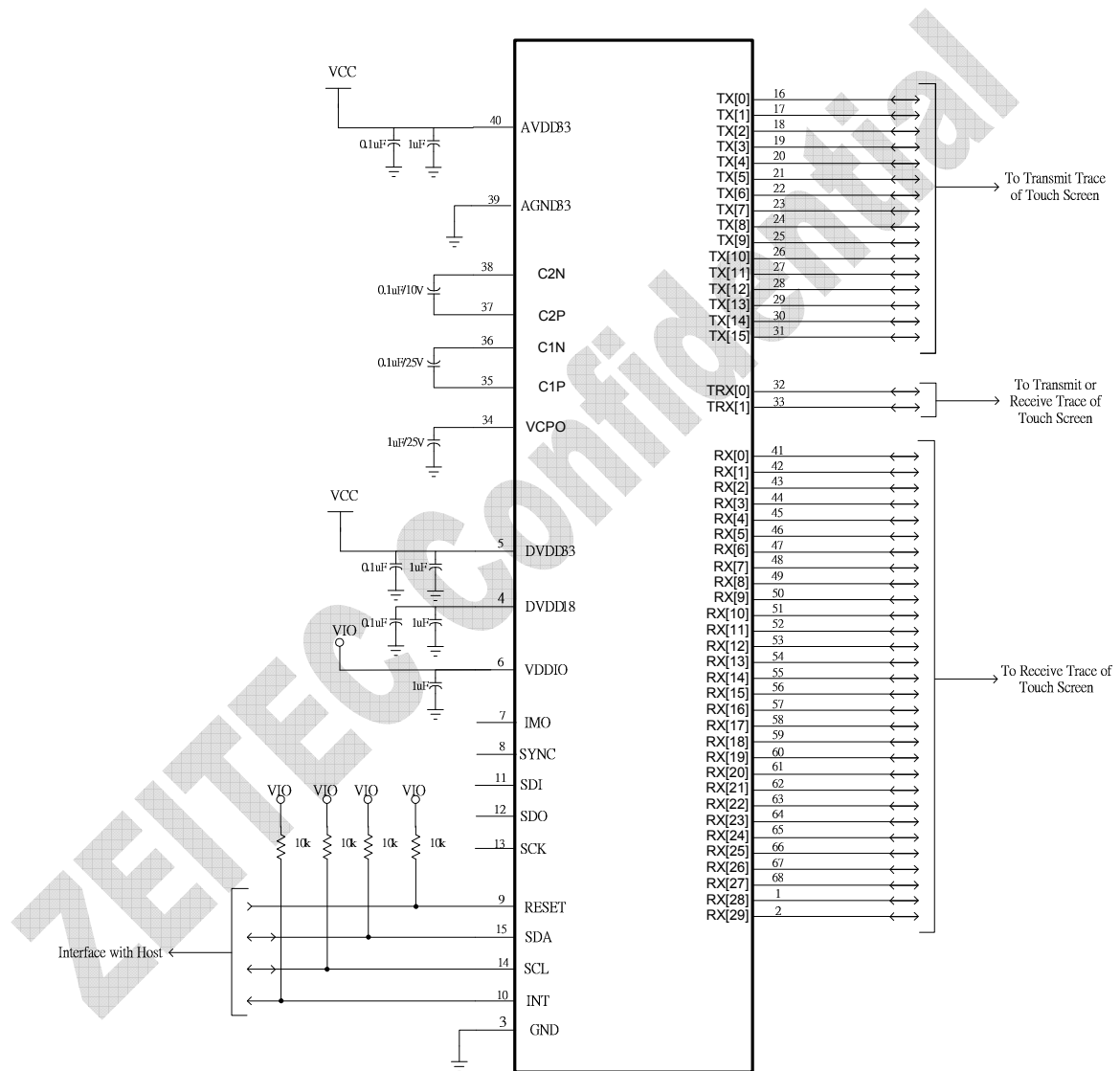



Figure 2-2 Zet6223 QFN68 Schematic Reference

2.4.2 I/O Voltage Selection

In the Figure 2-2, the interface voltage (VIO) and operation voltage (VCC) are separated for different I/O voltage application. On the condition, if the system needs the lower interface voltage than the operation voltage, it needs dual power

	Title	ZET6223 Product Specification	Date Originated: 29-Jun-12 Revision: 1.0
	ZEITEC Semiconductor	Doc #: ZP-HW-PS-0007	Date Revised: 1-Oct-12

supply from main board. One is for operation voltage and the other one is for interface voltage. Be carefully, the operation voltage must large than the interface voltage. It is showed in the Figure 2-3. The operation voltage is 3.3V and the interface voltage is 1.8V. So the interface I/O (SDA,SCL,RESET,INT) will work in 1.8V.

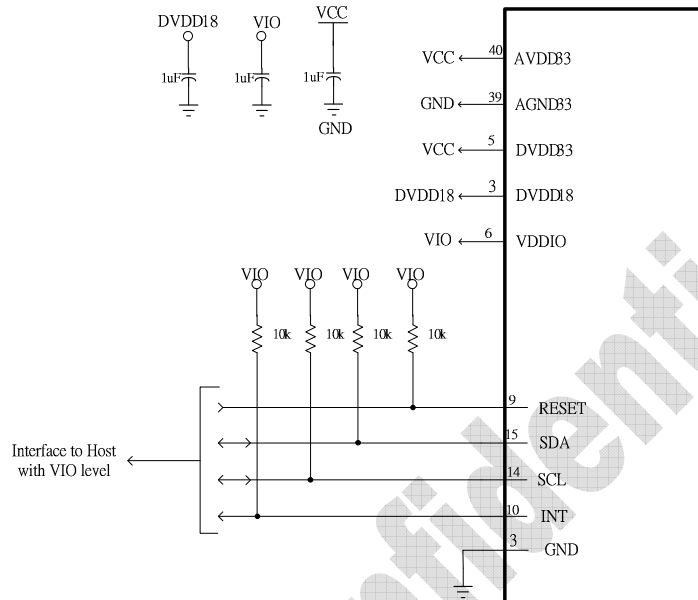

Figure 2-3 the Reference Schematic of Separated Power Supply

Another condition, if the system needs the lower interface voltage than the operation voltage, however, it was only one VCC power supplied from main board. It can be shorted the interface voltage (VIO) with digital 1.8V power supply DVDD18, generated by internal. Then, the interface I/O (SDA, SCL, RESET, INT) will work good in 1.8V level. It is showed in the Figure 2-4.

Finally, if the operation voltage and the interface voltage are the same, it just need only power supply and shorted the interface voltage (VIO) and operation voltage (VCC). So the interface I/O (SDA, SCL, RESET, and INT) will work in VCC level.

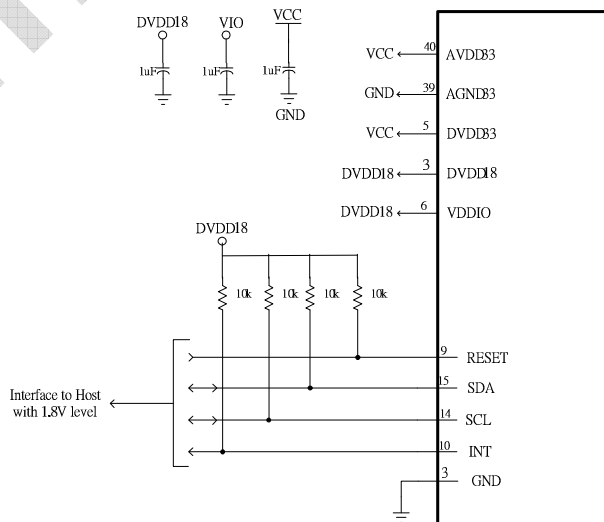



Figure 2-4 the Reference Schematic of Single VCC Power

	Title	ZET6223 Product Specification	Date Originated: 29-Jun-12
			Revision: 1.0
ZEITEC Semiconductor	Doc #:	ZP-HW-PS-0007	Date Revised: 1-Oct-12

3 TOUCH SCREEN LAYOUT

3.1 Resolution / DPI / Trace Number

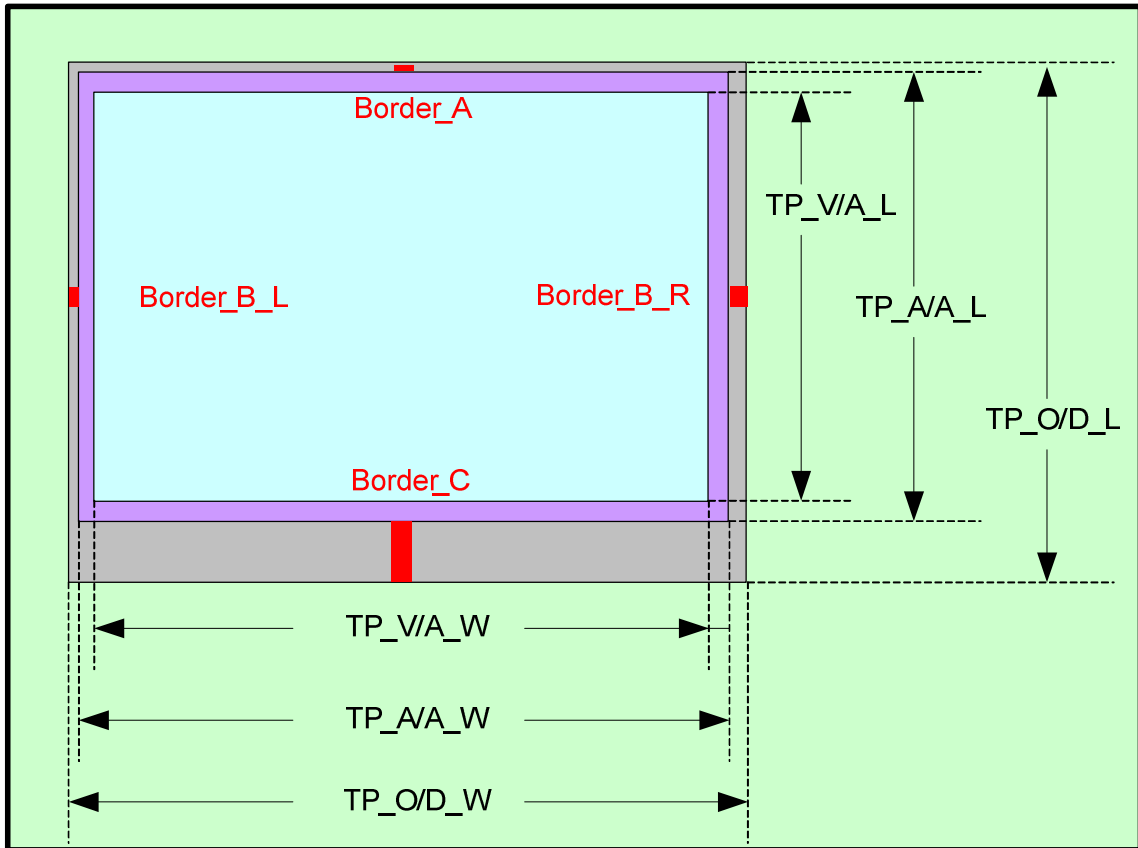



Figure 3-1 Touch Screen Outline Dimension

Table 3-1 Touch Screen Outline Define

AR	W : L
Sensor Size	S - inch
TP_O/D(Out Dimension)	W_OD : L_OD
TP_AA(Action Area)	W_AA : L_AA
TP_VA(View Area)	W_VA : L_VA
Border_A	W_Border_A
Border_B	W_Border_B
Border_C	W_Border_C
X_TraceNum	Num_X
Y_TraceNum	Num_Y
X Sensor Width	Wx
Y Sensor Width	Wy
ITO Layout	ITO Vendor Rule

	Title	ZET6223 Product Specification	Date Originated: 29-Jun-12
			Revision: 1.0
ZEITEC Semiconductor	Doc #: ZP-HW-PS-0007		Date Revised: 1-Oct-12

3.2 ITO Sensor Cell

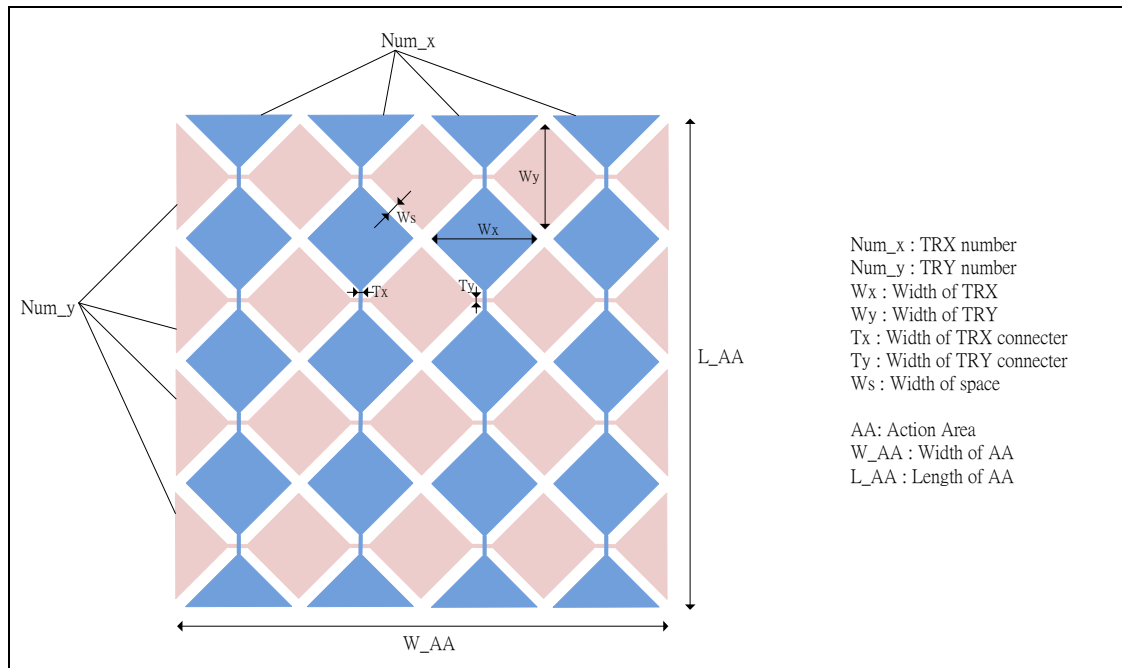

Figure 3-2 ITO Cell Parameter Define

3.2.1 Design Rule

(a) Design Reference Data

- LCM_AA = TP_VA => W_VA : L_VA
- FPCA Location
- TP_OD => W_OD : L_OD

(b) Sensor Design Rule

- Minimum Width between TP_AA and TP_VA = 1mm
- Trace Number :
 X-trace Number = Round(W_AA / Wx)
 Y-trace Number = Round(L_AA / Wy)
- Minimum Width between TP_OD and TP_AA in Border_A
 0.7mm (for Sensor OD cutting and one shielding line)
- Minimum Width between TP_OD and TP_AA in Border_B
 0.7mm (for Sensor OD cutting and one shielding line) + Trace Pitch *
 RoundUp (Y_TraceNum / 2) (for trace metal line)
- Minimum Width between TP_OD and TP_AA in Border_C
 0.7mm (for Sensor OD cutting and one shielding line) + Trace Pitch *
 RoundUp (Y_TraceNum + X_TraceNum) (for trace metal line)+ 1.6mm
 (for ACF area)
- Resistance between n-Trace and n+1 Trace must be the same.

(c) DPI && Resolution

- Resolution = (number of trace - 1) * 64
- DPI = Resolution / Inch

(d) TP_A/A_W (mm) = (Num_x * Wx) + (sqrt(2) * Ws * (Num_x - 1))

(e) TP_A/A_L (mm) = (Num_y * Wy) + (sqrt(2) * Ws * (Num_y - 1))

(f) $(Wx + Ws) < 6mm$,

	Title ZET6223 Product Specification	Date Originated: 29-Jun-12
		Revision: 1.0
ZEITEC Semiconductor	Doc #: ZP-HW-PS-0007	Date Revised: 1-Oct-12

for linearity (moving speed=20mm/s, 8ϕ) $\pm 1\text{mm}$ @ center area
 $\pm 2\text{mm}$ @ edge area (6mm)

3.2.2 Design Consideration

- Trace numbers depend on panel area and dots per inch (DPI).
- The sensitivity depends on the thickness of the cover lens. When the thickness is larger, the sensitivity will be smaller.
- To avoid pulling the big metallicity, for example, the metal screw or iron plat , beside the sensor trace.
- The sensor trace of X-axis and Y-axis can be any shape but it is better to be square, hexagon or octagon, as well as try to use all sensor area as many as possible.
- The connected line of X-axis and Y-axis sensor in the border region should be isolated by shielding ground.
- The shape and size of the same axis sensor cells should be the same between different traces.
- It is better that decreasing the total resistance of the sensor trace and the inaccuracy between the two neighbouring sensor trace should be less than 10% or 500Ω .
- It is better that decreasing the total capacitance of the sensor trace and the inaccuracy between the two neighbouring sensor trace should be less than 10% or 3pF.
- The product of total resistance and the total capacitance should be less than $1e-6$ ($R*C < 1e-6$).
- The total resistance of single trace (from IC to TP) should be less than $20k\Omega$.
- The total capacitance of single trace (from IC to TP) should be less than 60pF.
- The isolate resistance between sensor traces should be bigger than $10M\Omega$.

	Title	ZET6223 Product Specification	Date Originated: 29-Jun-12
			Revision: 1.0
ZEITEC Semiconductor	Doc #: ZP-HW-PS-0007		Date Revised: 1-Oct-12

3.3 Touch Screen Design example

3.3.1 10.1" 48ch (TX : RX = 18 : 30) Touch Solution

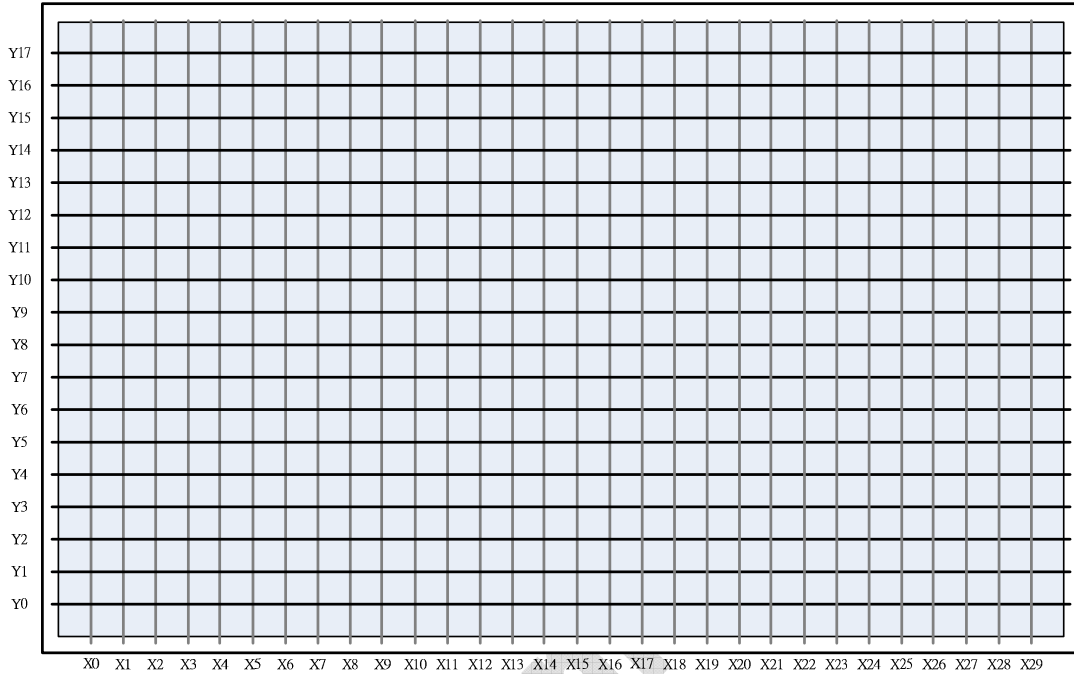

Figure 3-3 10.1" 48ch (TX : RX = 18 : 30) Touch Screen ,Origin at (X0,Y0)

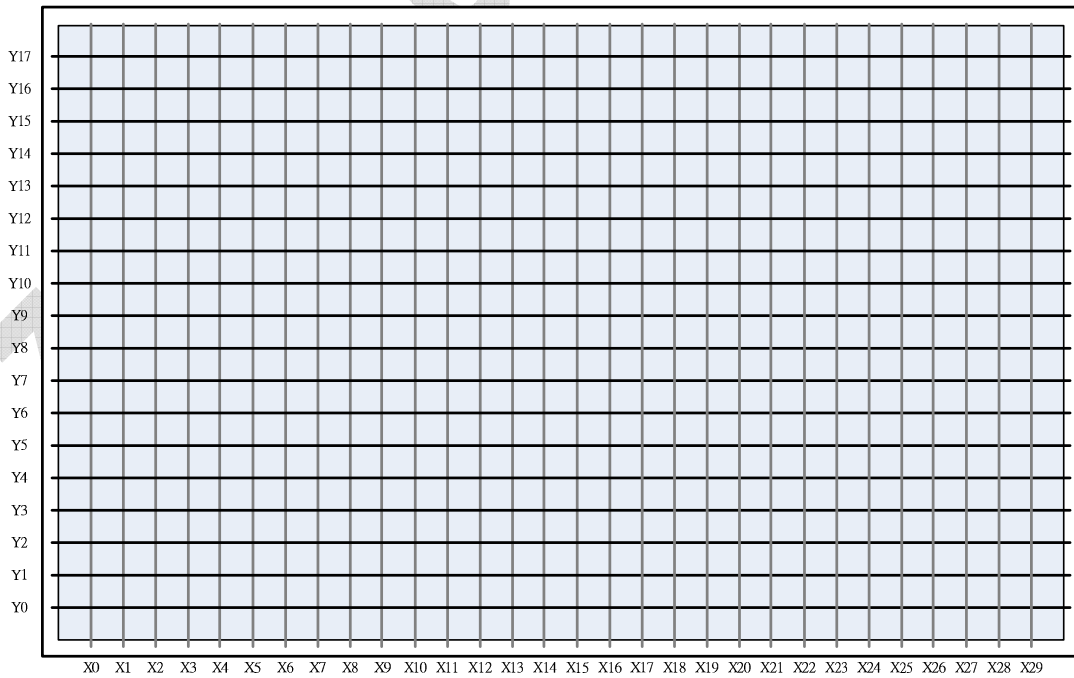



Figure 3-3 shows a touch screen, X trace number=30 and Y trace number=18. The total trace number is 48 and ZEITEC Touch solution IC package ZET6223 QFN68 (TX:RX=18:30) is the right choice. The connection of touch panel traces

	Title	ZET6223 Product Specification	Date Originated: 29-Jun-12
			Revision: 1.0
ZEITEC Semiconductor	Doc #: ZP-HW-PS-0007		Date Revised: 1-Oct-12

and IC pin are as listed in Table 3-2. And It was set the driving trace as Y0~Y17 and the sensing trace as X0~X29. And one shielding ground MUST be insert between TX and RX traces.

Table 3-2 Touch Panel for ZET6223 Design Table

Touchscreen	Zet6223 QFN68		
Ground Ring	GND	X25	RX[25]
X0	RX[0]	X26	RX[26]
X1	RX[1]	X27	RX[27]
X2	RX[2]	X28	RX[28]
X3	RX[3]	X29	RX[29]
X4	RX[4]	Shielding Ground	GND
X5	RX[5]	Y0	TX[0]
X6	RX[6]	Y1	TX[1]
X7	RX[7]	Y2	TX[2]
X8	RX[8]	Y3	TX[3]
X9	RX[9]	Y4	TX[4]
X10	RX[10]	Y5	TX[5]
X11	RX[11]	Y6	TX[6]
X12	RX[12]	Y7	TX[7]
X13	RX[13]	Y8	TX[8]
X14	RX[14]	Y9	TX[9]
X15	RX[15]	Y10	TX[10]
X16	RX[16]	Y11	TX[11]
X17	RX[17]	Y12	TX[12]
X18	RX[18]	Y13	TX[13]
X19	RX[19]	Y14	TX[14]
X20	RX[20]	Y15	TX[15]
X21	RX[21]	Y16	TRX[0]
X22	RX[22]	Y17	TRX[1]
X23	RX[23]	Ground Ring	GND
X24	RX[24]	NA	

	Title	ZET6223 Product Specification	Date Originated: 29-Jun-12
			Revision: 1.0
ZEITEC Semiconductor	Doc #:	ZP-HW-PS-0007	Date Revised: 1-Oct-12

4 INTERFACE AND COMMUNICATION TIMING

4.1 Pin Description

Table 4-1 Pin Description

Pin	Symbol	I/O	Description
1	VCC	PWR	Power supply voltage source.
2	SDA	I/O	For Inter-IC interface (I2C) mode. Data input as slave device and output as master device.
3	SCL	I/O	For Inter-IC interface (I2C) mode. Clock input as slave device and output as master device.
4	GND	PWR	Ground voltage source.
5	Reset	I	Reset ZET6223, active low
6	/INT	O	Interrupt output signal.

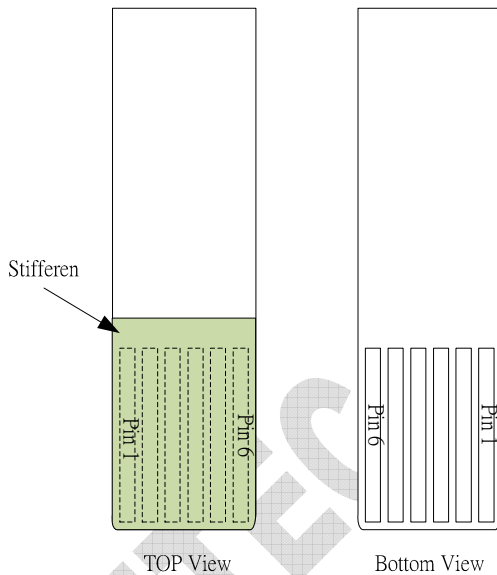



Figure 4-1 I2C Pin Define

4.2 I2C Slave Mode

For I2C slave mode selection, the SDA and SCL signal lines have to be pulled-high with R resistor (See Figure 4-2). The internal resistor of SDA and SCL is $4.7K\Omega \pm 20\%$ and it can be enable or disable by Zeki (default enable). The TP is processing data on the I2C bus, the Touch Panel controller of TP uses the 7-bit addressing Mode and supports the bit transfer rate both of Standard-mode (up to 100 kbps) and Fast-mode (up to 400 kbps).

	Title	ZET6223 Product Specification	Date Originated: 29-Jun-12
			Revision: 1.0
ZEITEC Semiconductor	Doc #: ZP-HW-PS-0007		Date Revised: 1-Oct-12

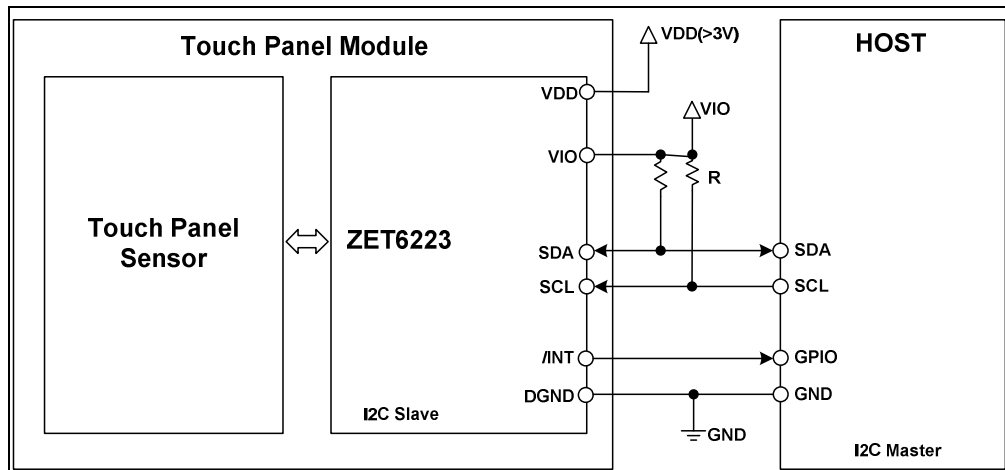

Figure 4-2 Connection between Touch Panel and Host in I2C Slave Mode

4.3 I2C Slave Mode Communication Address

The Touch Panel controller is defined as an I2C slave device and the Host is defined as a master. The device address of the Touch Panel controller is designed as 7-bit address mode. The Touch Panel controller address is defined as 0x76 and LSB of I2C address register is Read / Write bit as shown below.

Table 4-2 I2C Address

	MSB							LSB
I2C Address	1	1	1	0	1	1	0	R/W

The first seven bits of I2C address register is device address of TP and the 8th bit means that Host wants to read data from Slave device or write data to Slave device (R(Read) = 1 and W (Write) = 0).

4.4 I2C Slave Mode Communication Dynamic Format

Device transmit X/Y coordinate to host and the packet ID is 0x3C

Protocol: When Host discovers /INT pull low, Host sends clock to receive information, the duration between byte and byte is at least 30us. The Coordinate TX Mode is Dynamic format, according to different Finger Application; the Coordinate TX Mode can support different Transmission data length.

- One Finger Application : total 7 bytes
1 Packet ID Byte, 2 Valid Bytes, and 4 Finger1 Coordinate Bytes in sequence.
- One Finger + Key Application : total 8 bytes
1 Packet ID Byte, 2 Valid Bytes, 4 Finger1 Coordinate Bytes, 1 Key Byte in sequence.
- Two Fingers Application : total 11 bytes

	Title	ZET6223 Product Specification	Date Originated: 29-Jun-12 Revision: 1.0
	ZEITEC Semiconductor	Doc #: ZP-HW-PS-0007	Date Revised: 1-Oct-12

1 Packet ID Byte, 2 Valid Bytes, 4 Finger1 Coordinate Bytes, 4 Finger2 Coordinate bytes in sequence.

- Two Fingers + key Application : total 12 bytes
1 Packet ID Byte, 2 Valid Bytes, 4 Finger1 Coordinate bytes, 4 Finger2 Coordinate bytes, 1 Key Byte in sequence.
- Four Fingers Application : total 19 bytes
1 Packet ID Byte, 2 Valid Bytes, 4 Finger1 Coordinate bytes, 4 Finger2 Coordinate bytes, 4 Finger3 Coordinate bytes, 4 Finger4 Coordinate bytes in sequence.
- Four Fingers + Key Application : total 20 bytes
1 Packet ID Byte, 2 Valid Bytes, 4 Finger1 Coordinate bytes, 4 Finger2 Coordinate bytes, 4 Finger3 Coordinate bytes, 4 Finger4 Coordinate bytes, 1 Key Byte in sequence.
- Five Fingers Application : total 23 bytes
1 Packet ID Byte, 2 Valid Bytes, 4 Finger1 Coordinate bytes, 4 Finger2 Coordinate bytes, 4 Finger3 Coordinate bytes, 4 Finger4 Coordinate bytes, 4 Finger5 Coordinate bytes in sequence
- Five Fingers + Key Application : total 24 bytes
1 Packet ID Byte, 2 Valid Bytes, 4 Finger1 Coordinate bytes, 4 Finger2 Coordinate bytes, 4 Finger3 Coordinate bytes, 4 Finger4 Coordinate bytes, 4 Finger5 Coordinate bytes, 1 Key Byte in sequence
- Ten Fingers Application : total 43 bytes
1 Packet ID Byte, 2 Valid Bytes, 4 Finger1 Coordinate bytes, 4 Finger2 Coordinate bytes, ..., 4 Finger10 Coordinate bytes in sequence.
- Ten Fingers + Key Application : 24 bytes
1 Packet ID Byte, 2 Valid Bytes, 4 Finger1 Coordinate bytes, 4 Finger2 Coordinate bytes, ..., 4 Finger10 Coordinate bytes, 1 Key Byte in sequence.

Every Finger has four-byte information, 1st byte ~ 3rd byte are the X/Y coordinate, Last byte is the Z-Domain information that means the Touch Press Strength.

If Key Function was enabled, the Key Byte will be placed in the last byte of Coordinate Transmission data, maximum supported Key Number is 8 keys.

Figure 4-3 ~ Figure 4-9 shows the TX Data Timing of Five Fingers + Key Application.

	Title ZET6223 Product Specification	Date Originated: 29-Jun-12
		Revision: 1.0
ZEITEC Semiconductor	Doc #: ZP-HW-PS-0007	Date Revised: 1-Oct-12

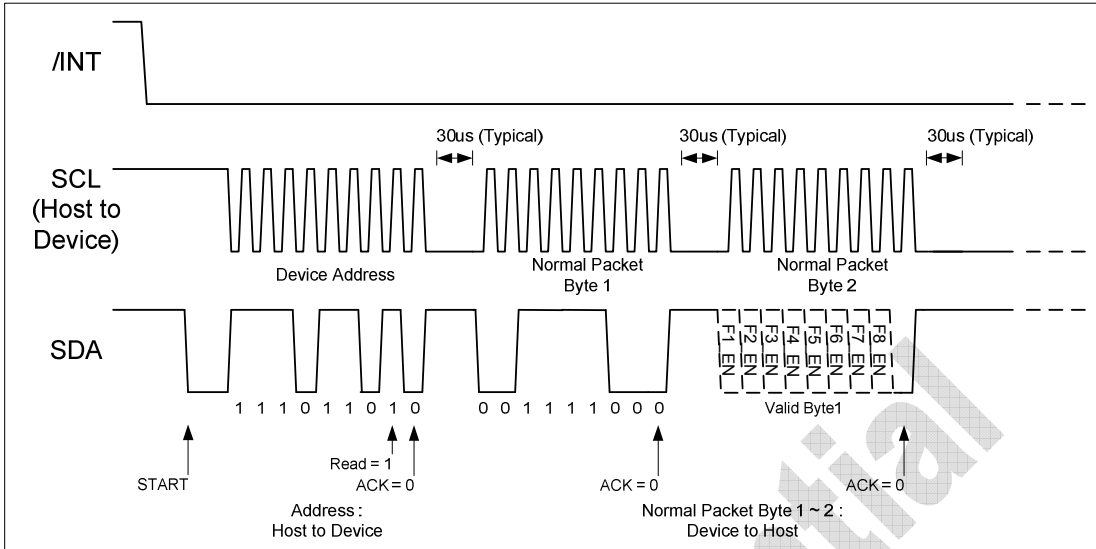

Figure 4-3 Packet – Byte 1 ~ Byte 2

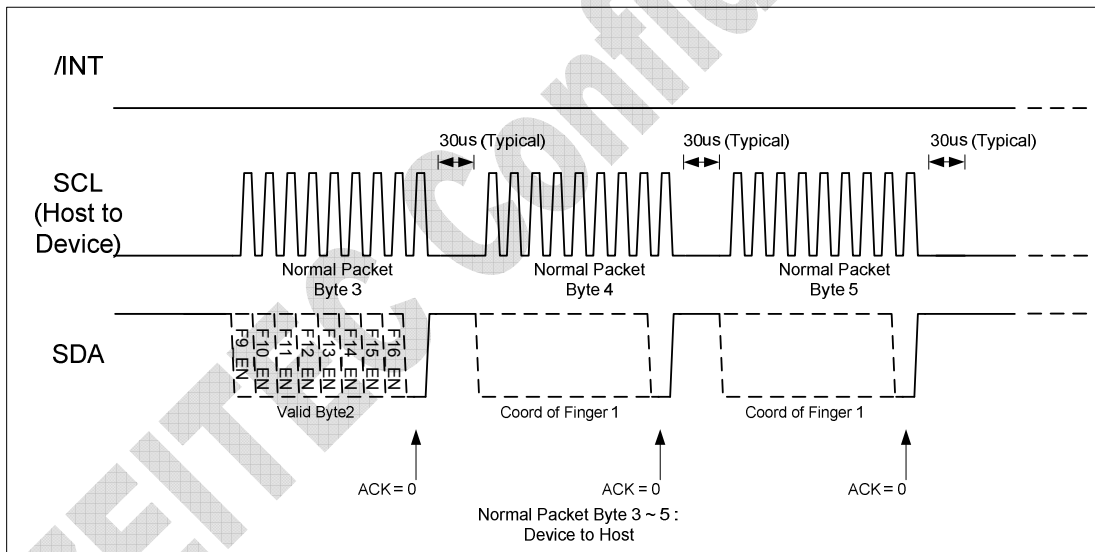



Figure 4-4 Packet – Byte 3 ~ Byte 5

	Title ZET6223 Product Specification	Date Originated: 29-Jun-12
		Revision: 1.0
ZEITEC Semiconductor	Doc #: ZP-HW-PS-0007	Date Revised: 1-Oct-12

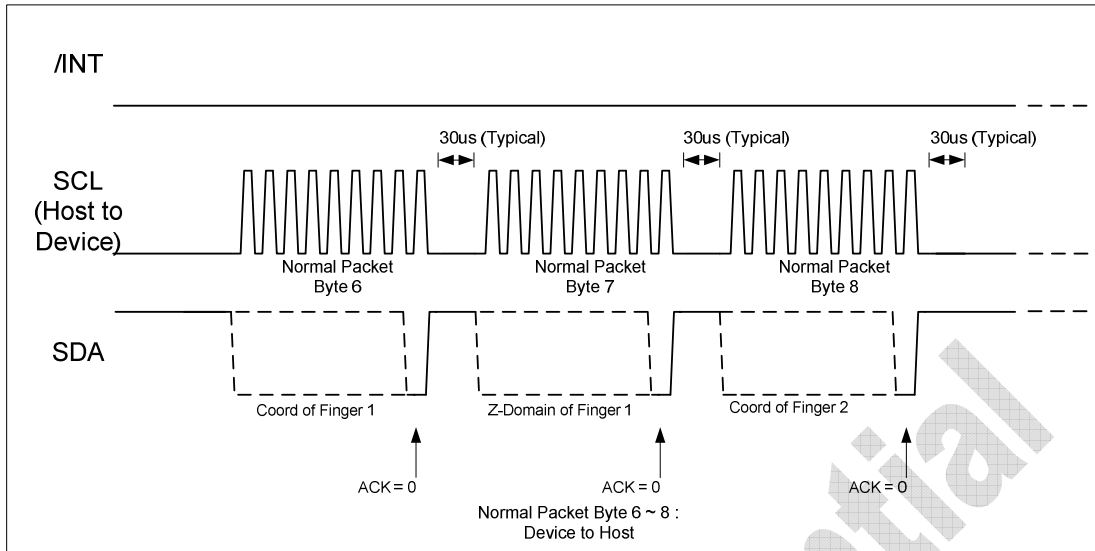

Figure 4-5 Packet - Byte 6 ~ Byte 8

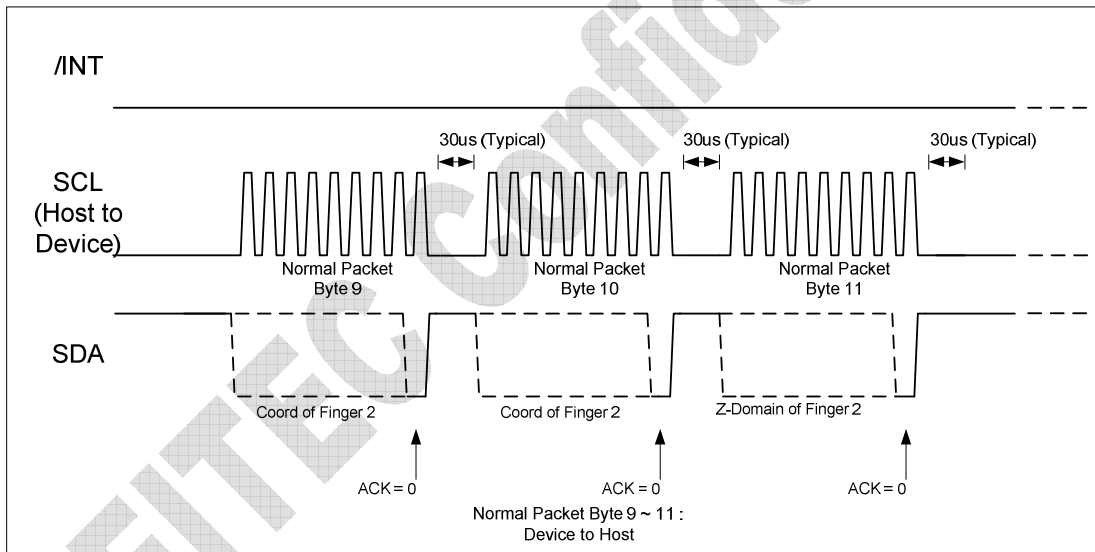



Figure 4-6 Packet - Byte 9 ~ Byte 11

	Title ZET6223 Product Specification	Date Originated: 29-Jun-12 Revision: 1.0
	Doc #: ZP-HW-PS-0007	Date Revised: 1-Oct-12

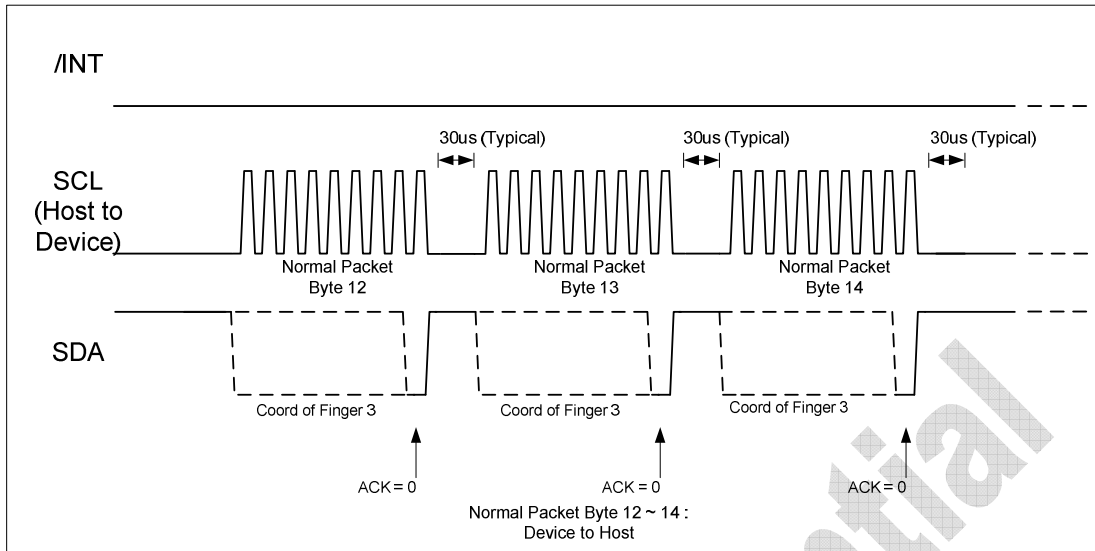

Figure 4-7 Packet - Byte 12 ~ Byte 14

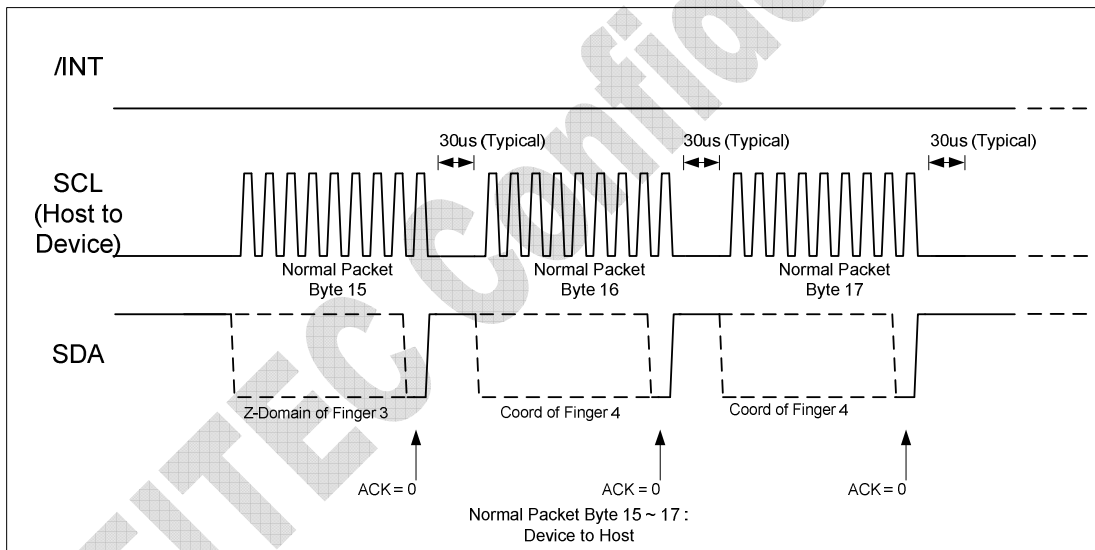



Figure 4-8 Packet - Byte 15 ~ Byte 17

	Title ZET6223 Product Specification	Date Originated: 29-Jun-12
		Revision: 1.0
ZEITEC Semiconductor	Doc #: ZP-HW-PS-0007	Date Revised: 1-Oct-12

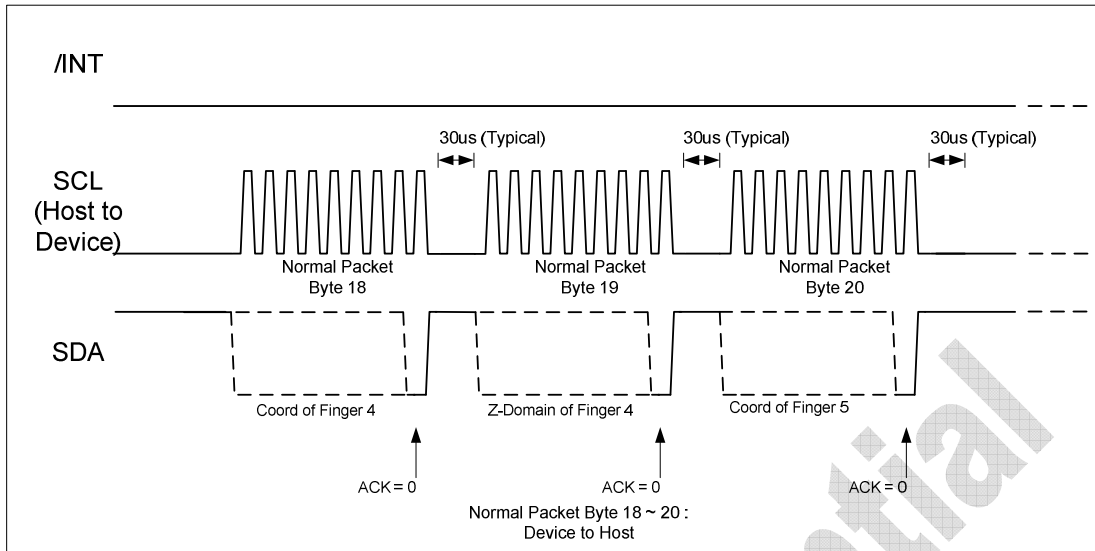

Figure 4-9 Packet – Byte 18 ~ Byte 20

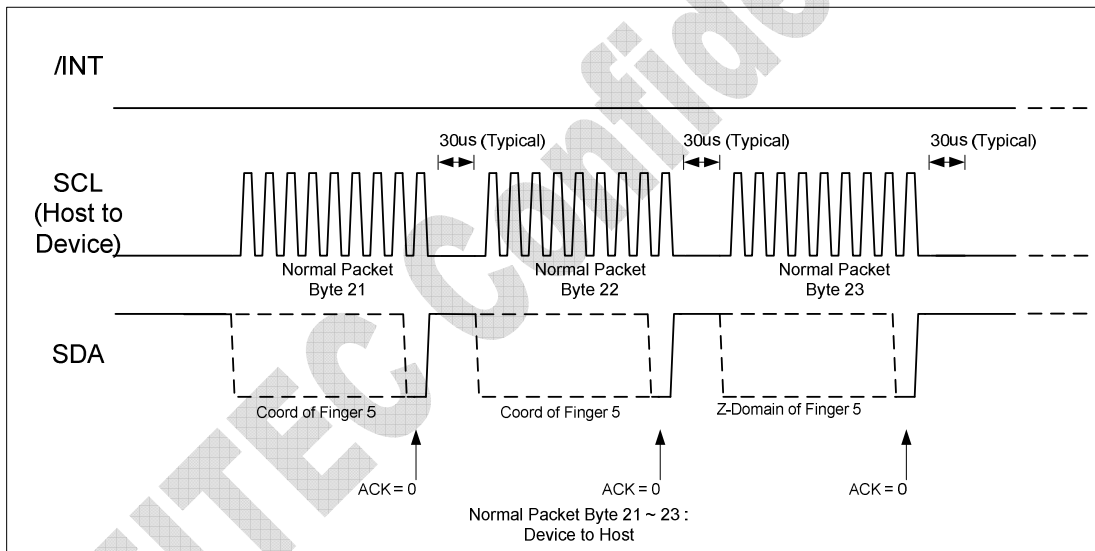



Figure 4-10 Packet – Byte 21 ~ Byte 23

	Title ZET6223 Product Specification	Date Originated: 29-Jun-12 Revision: 1.0
	Doc #: ZP-HW-PS-0007	Date Revised: 1-Oct-12

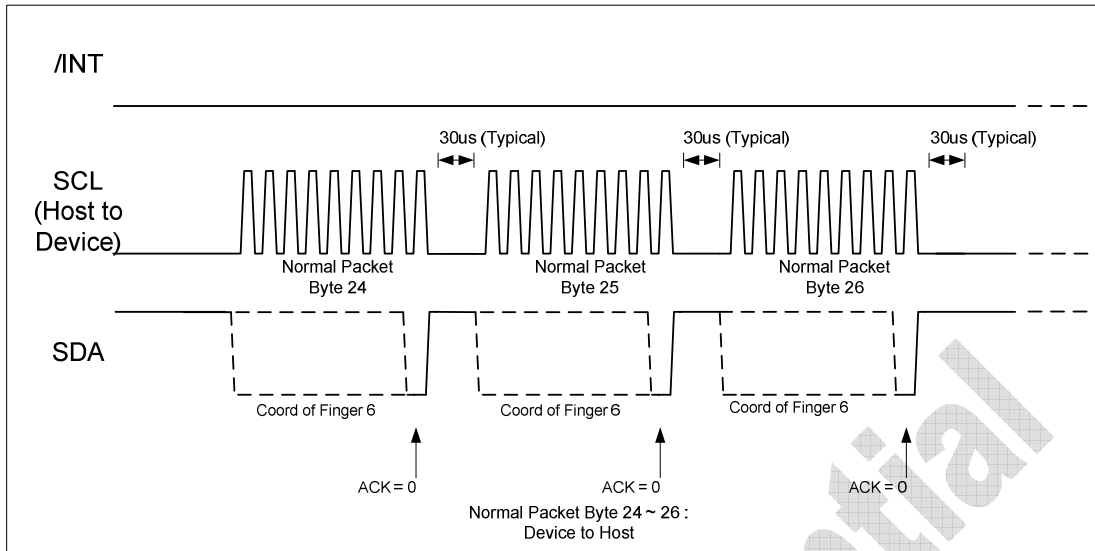

Figure 4-11 Packet – Byte 24 ~ Byte 26

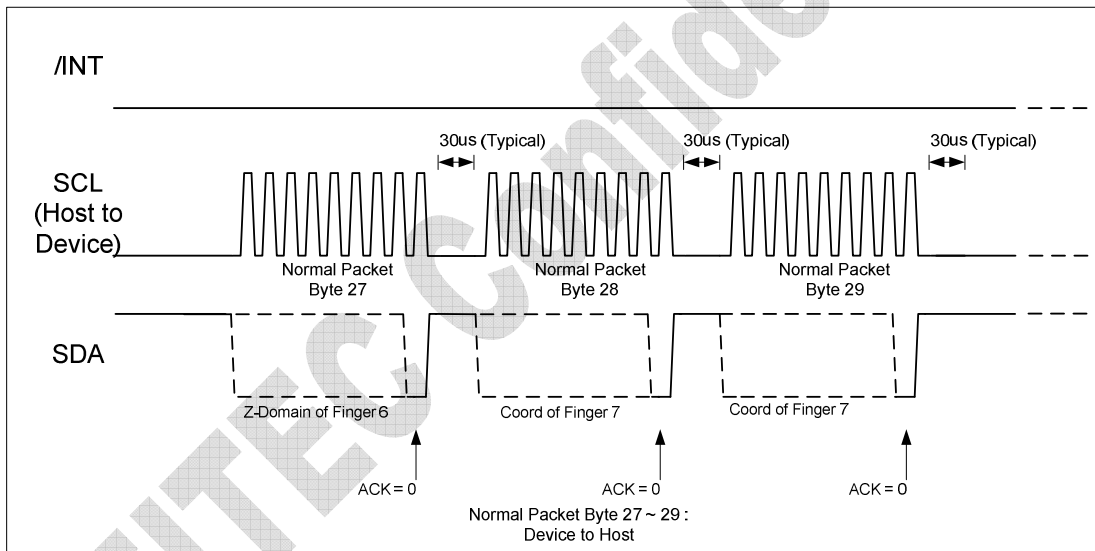



Figure 4-12 Packet – Byte 27 ~ Byte 29

	Title ZET6223 Product Specification	Date Originated: 29-Jun-12 Revision: 1.0
	Doc #: ZP-HW-PS-0007	Date Revised: 1-Oct-12

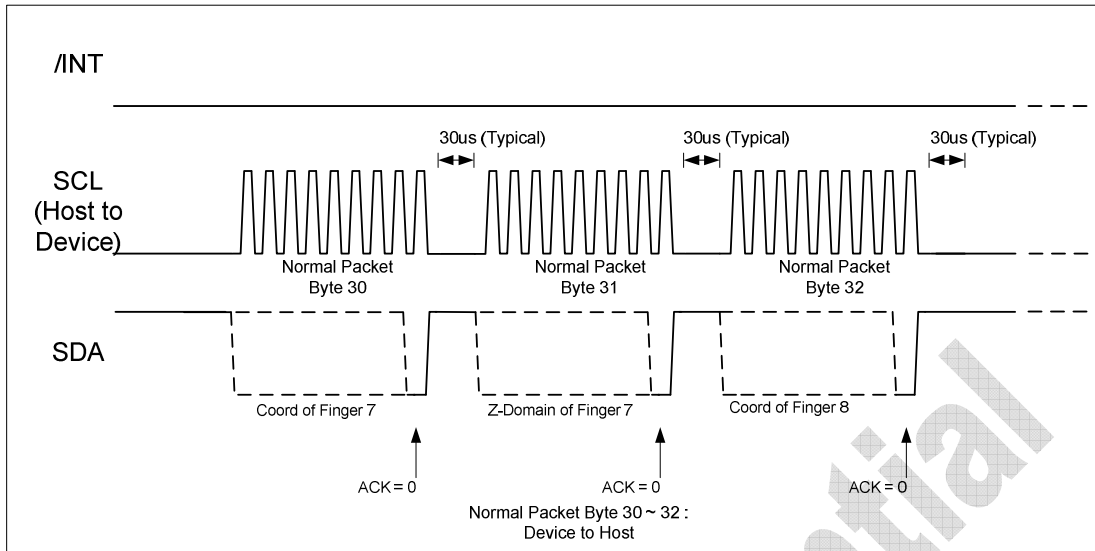

Figure 4-13 Packet – Byte 30 ~ Byte 32

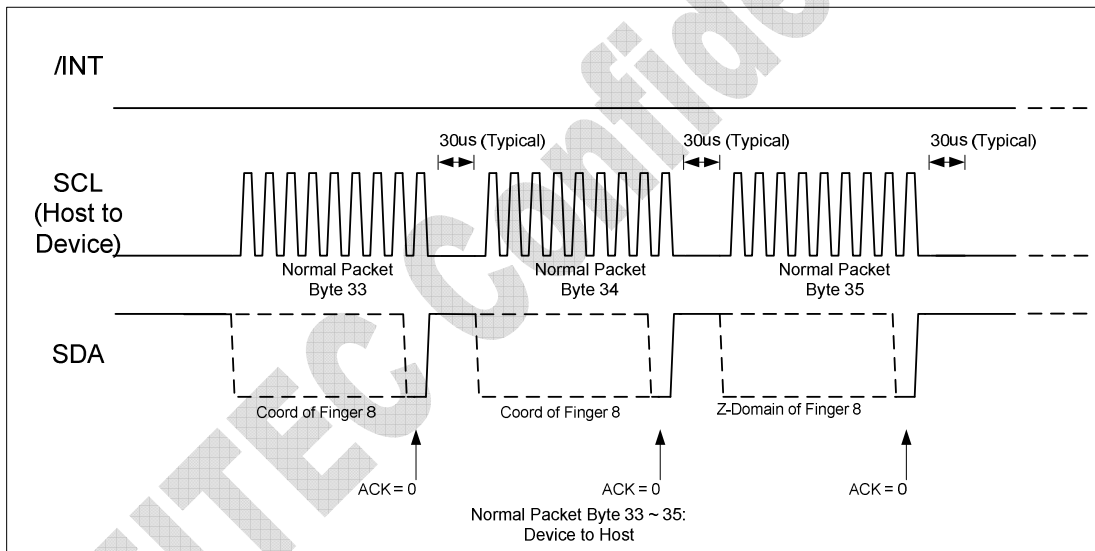



Figure 4-14 Packet – Byte 33 ~ Byte 35

	Title ZET6223 Product Specification	Date Originated: 29-Jun-12 Revision: 1.0
	Doc #: ZP-HW-PS-0007	Date Revised: 1-Oct-12

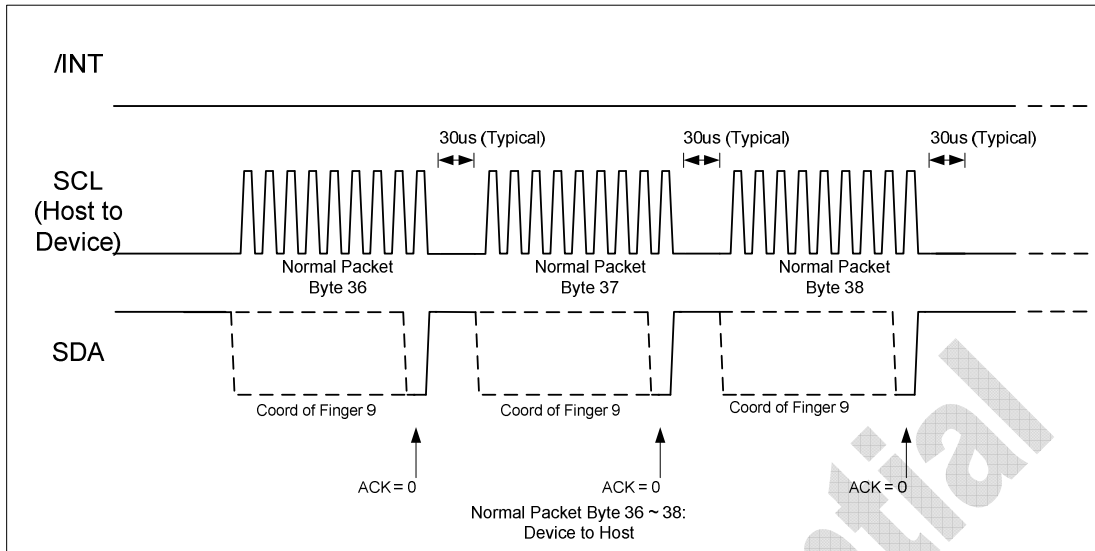

Figure 4-15 Packet – Byte 36 ~ Byte 38

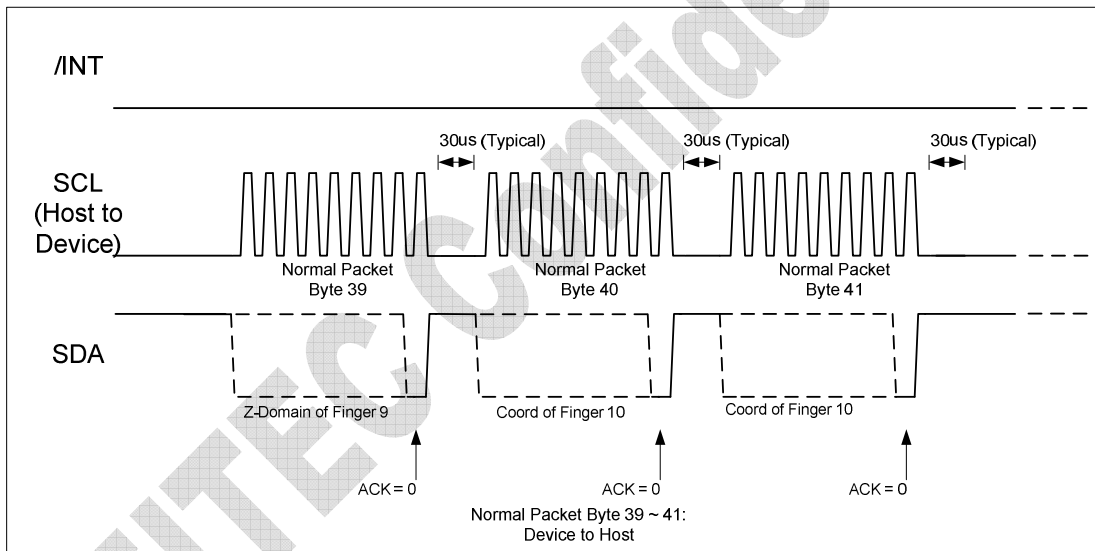



Figure 4-16 Packet – Byte 39 ~ Byte 41

	Title ZET6223 Product Specification	Date Originated: 29-Jun-12
		Revision: 1.0
ZEITEC Semiconductor	Doc #: ZP-HW-PS-0007	Date Revised: 1-Oct-12

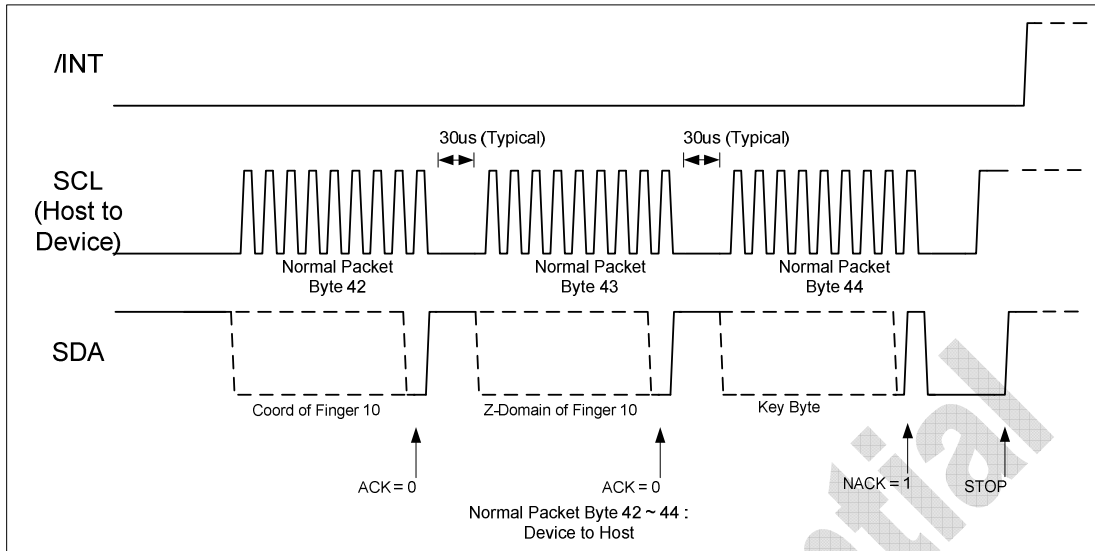



Figure 4-17 Packet – Byte 42 ~ Byte 44

ZEITEC Confidential

	Title	ZET6223 Product Specification	Date Originated: 29-Jun-12
			Revision: 1.0
ZEITEC Semiconductor	Doc #: ZP-HW-PS-0007		Date Revised: 1-Oct-12

4.4.1 Dynamic Coordinate TX Normal Packet (Touch Panel to Host)

Table 4-3 24 Bytes Data Format (Five Fingers + Key Application)

Byte No.	Bit No.	7	6	5	4	3	2	1	0
1		0	0	1	1	1	1	0	0
2		F1_EN	F2_EN	F3_EN	F4_EN	F5_EN	F6_EN	F7_EN	F8_EN
3		F9_EN	F10_EN	F11_EN	F12_EN	F13_EN	F14_EN	F15_EN	F16_EN
4		F1_X11	F1_X10	F1_X09	F1_X08	F1_Y11	F1_Y10	F1_Y09	F1_Y08
5		F1_X07	F1_X06	F1_X05	F1_X04	F1_X03	F1_X02	F1_X01	F1_X00
6		F1_Y07	F1_Y06	F1_Y05	F1_Y04	F1_Y03	F1_Y02	F1_Y01	F1_Y00
7		0	0	0	F1_Z04	F1_Z03	F1_Z02	F1_Z01	F1_Z00
8		F2_X11	F2_X10	F2_X09	F2_X08	F2_Y11	F2_Y10	F2_Y09	F2_Y08
9		F2_X07	F2_X06	F2_X05	F2_X04	F2_X03	F2_X02	F2_X01	F2_X00
10		F2_Y07	F2_Y06	F2_Y05	F2_Y04	F2_Y03	F2_Y02	F2_Y01	F2_Y00
11		0	0	0	F2_Z04	F2_Z03	F2_Z02	F2_Z01	F2_Z00
12		F3_X11	F3_X10	F3_X09	F3_X08	F3_Y11	F3_Y10	F3_Y09	F3_Y08
13		F3_X07	F3_X06	F3_X05	F3_X04	F3_X03	F3_X02	F3_X01	F3_X00
14		F3_Y07	F3_Y06	F3_Y05	F3_Y04	F3_Y03	F3_Y02	F3_Y01	F3_Y00
15		0	0	0	F3_Z04	F3_Z03	F3_Z02	F3_Z01	F3_Z00
16		F4_X11	F4_X10	F4_X09	F4_X08	F4_Y11	F4_Y10	F4_Y09	F4_Y08
17		F4_X07	F4_X06	F4_X05	F4_X04	F4_X03	F4_X02	F4_X01	F4_X00
18		F4_Y07	F4_Y06	F4_Y05	F4_Y04	F4_Y03	F4_Y02	F4_Y01	F4_Y00
19		0	0	0	F4_Z04	F4_Z03	F4_Z02	F4_Z01	F4_Z00
20		F5_X11	F5_X10	F5_X09	F5_X08	F5_Y11	F5_Y10	F5_Y09	F5_Y08
21		F5_X07	F5_X06	F5_X05	F5_X04	F5_X03	F5_X02	F5_X01	F5_X00
22		F5_Y07	F5_Y06	F5_Y05	F5_Y04	F5_Y03	F5_Y02	F5_Y01	F5_Y00
23		0	0	0	F5_Z04	F5_Z03	F5_Z02	F5_Z01	F5_Z00
24		F6_X11	F6_X10	F6_X09	F6_X08	F6_Y11	F6_Y10	F6_Y09	F6_Y08
25		F6_X07	F6_X06	F6_X05	F6_X04	F6_X03	F6_X02	F6_X01	F6_X00
26		F6_Y07	F6_Y06	F6_Y05	F6_Y04	F6_Y03	F6_Y02	F6_Y01	F6_Y00
27		0	0	0	F6_Z04	F6_Z03	F6_Z02	F6_Z01	F6_Z00
28		F7_X11	F7_X10	F7_X09	F7_X08	F7_Y11	F7_Y10	F7_Y09	F7_Y08
29		F7_X07	F7_X06	F7_X05	F7_X04	F7_X03	F7_X02	F7_X01	F7_X00
30		F7_Y07	F7_Y06	F7_Y05	F7_Y04	F7_Y03	F7_Y02	F7_Y01	F7_Y00
31		0	0	0	F7_Z04	F7_Z03	F7_Z02	F7_Z01	F7_Z00
32		F8_X11	F8_X10	F8_X09	F8_X08	F8_Y11	F8_Y10	F8_Y09	F8_Y08
33		F8_X07	F8_X06	F8_X05	F8_X04	F8_X03	F8_X02	F8_X01	F8_X00
34		F8_Y07	F8_Y06	F8_Y05	F8_Y04	F8_Y03	F8_Y02	F8_Y01	F8_Y00
35		0	0	0	F8_Z04	F8_Z03	F8_Z02	F8_Z01	F8_Z00
36		F9_X11	F9_X10	F9_X09	F9_X08	F9_Y11	F9_Y10	F9_Y09	F9_Y08
37		F9_X07	F9_X06	F9_X05	F9_X04	F9_X03	F9_X02	F9_X01	F9_X00
38		F9_Y07	F9_Y06	F9_Y05	F9_Y04	F9_Y03	F9_Y02	F9_Y01	F9_Y00
39		0	0	0	F9_Z04	F9_Z03	F9_Z02	F9_Z01	F9_Z00

	Title	ZET6223 Product Specification	Date Originated: 29-Jun-12
			Revision: 1.0
ZEITEC Semiconductor	Doc #:	ZP-HW-PS-0007	Date Revised: 1-Oct-12

40	F10_X11	F10_X10	F10_X09	F10_X08	F10_Y11	F10_Y10	F10_Y09	F10_Y08
41	F10_X07	F10_X06	F10_X05	F10_X04	F10_X03	F10_X02	F10_X01	F10_X00
42	F10_Y07	F10_Y06	F10_Y05	F10_Y04	F10_Y03	F10_Y02	F10_Y01	F10_Y00
43	0	0	0	F10_Z04	F10_Z03	F10_Z02	F10_Z01	F10_Z00
44	K8_EN	K7_EN	K6_EN	K5_EN	K4_EN	K3_EN	K2_EN	K1_EN

Data Format of X/Y Coordinate

Normal Packet: 24 Bytes

- Packet ID: 0x3C (**Byte 1**)
- Valid Byte (**Byte2 and Byte3**)
 - (a) FX_EN = 1 : Coordinate of Finger X is meaningful.
 - (b) Total 16-Finger Valid bits can be supported in the two bytes, if the valid bit of Finger X is high, Host can catch the Coordinate of Finger X from the coordinate bytes of Finger X.

Table 4-4 Byte2 and Byte3

MSB								LSB
F1_EN	F2_EN	F3_EN	F4_EN	F5_EN	F6_EN	F7_EN	F8_EN	
MSB								LSB
F9_EN	F10_EN	F11_EN	F12_EN	F13_EN	F14_EN	F15_EN	F16_EN	

- X-axis Coordinate of Finger 1 (**MSB 4 bits of Byte4 and 8 bits of Byte5**):
 - (a) Total 12 Bits format
 - (b) X1-axis Coordinate Format

Table 4-5 MSB 4 Bits of Byte4 and 8 Bits of Byte5

MSB											LSB
F1 X11	F1 X10	F1 X09	F1 X08	F1 X07	F1 X06	F1 X05	F1 X04	F1 X03	F1 X02	F1 X01	F1 X00

- Y-axis Coordinate of Finger 1 (**LSB 4 bits of Byte4 and 8 bits of Byte6**):
 - (a) Total 12 Bits format
 - (b) Y1-axis Coordinate Format

Table 4-6 LSB 4 Bits of Byte4 and 8 Bits of Byte6

MSB											LSB
F1 Y11	F1 Y10	F1 Y09	F1 Y08	F1 Y07	F1 Y06	F1 Y05	F1 Y04	F1 Y03	F1 Y02	F1 Y01	F1 Y00

- X-axis Coordinate of Finger 2 (**MSB 4 bits of Byte8 and 8 bits of Byte9**):
 - (a) Total 12 Bits format
 - (b) X2-axis Coordinate Format

	Title ZET6223 Product Specification	Date Originated: 29-Jun-12
		Revision: 1.0
ZEITEC Semiconductor	Doc #: ZP-HW-PS-0007	Date Revised: 1-Oct-12

Table 4-7 MSB 4 Bits of Byte8 and 8 Bits of Byte9

MSB											LSB
F2 X11	F2 X10	F2 X09	F2 X08	F2 X07	F2 X06	F2 X05	F2 X04	F2 X03	F2 X02	F2 X01	F2 X00

- Y-axis Coordinate of Finger 2 (**LSB 4 bits of Byte8 and 8 bits of Byte10**):
 - (a) Total 12 Bits format
 - (b) Y2-axis Coordinate Format

Table 4-8 LSB 4 bits of Byte8 and 8 Bits of Byte10

MSB											LSB
F2 Y11	F2 Y10	F2 Y09	F2 Y08	F2 Y07	F2 Y06	F2 Y05	F2 Y04	F2 Y03	F2 Y02	F2 Y01	F2 Y00

- X-axis Coordinate of Finger 3 (**MSB 4 bits of Byte12 and 8 bits of Byte13**):
 - (a) Total 12 Bits format
 - (b) X3-axis Coordinate Format

Table 4-9 MSB 4 Bits of Byte12 and 8 Bits of Byte13

MSB											LSB
F3 X11	F3 X10	F3 X09	F3 X08	F3 X07	F3 X06	F3 X05	F3 X04	F3 X03	F3 X02	F3 X01	F3 X00

- Y-axis Coordinate of Finger 3 (**LSB 4 bits of Byte12 and 8 bits of Byte14**):
 - (a) Total 12 Bits format
 - (b) Y3-axis Coordinate Format

Table 4-10 LSB 4 Bits of Byte12 and 8 Bits of Byte14

MSB											LSB
F3 Y11	F3 Y10	F3 Y09	F3 Y08	F3 Y07	F3 Y06	F3 Y05	F3 Y04	F3 Y03	F3 Y02	F3 Y01	F3 Y00

- X-axis Coordinate of Finger 4 (**MSB 4 bits of Byte16 and 8 bits of Byte17**):
 - (a) Total 12 Bits format
 - (b) X4-axis Coordinate Format

Table 4-11 MSB 4 Bits of Byte16 and 8 Bits of Byte17

MSB											LSB
F4 X11	F4 X10	F4 X09	F4 X08	F4 X07	F4 X06	F4 X05	F4 X04	F4 X03	F4 X02	F4 X01	F4 X00

	Title	ZET6223 Product Specification	Date Originated: 29-Jun-12
			Revision: 1.0
ZEITEC Semiconductor	Doc #: ZP-HW-PS-0007		Date Revised: 1-Oct-12

- Y-axis Coordinate of Finger 4 (**LSB 4 bits of Byte16 and 8 bits of Byte18**):
 - (a) Total 12 Bits format
 - (b) Y4-axis Coordinate Format

Table 4-12 LSB 4 Bits of Byte16 and 8 Bits of Byte18

MSB												LSB
F4 Y11	F4 Y10	F4 Y09	F4 Y08	F4 Y07	F4 Y06	F4 Y05	F4 Y04	F4 Y03	F4 Y02	F4 Y01	F4 Y00	

- X-axis Coordinate of Finger 5 (**MSB 4 bits of Byte20 and 8 bits of Byte21**):
 - (a) Total 12 Bits format
 - (b) X5-axis Coordinate Format

Table 4-13 MSB 4 Bits of Byte20 and 8 Bits of Byte21

MSB												LSB
F5 X11	F5 X10	F5 X09	F5 X08	F5 X07	F5 X06	F5 X05	F5 X04	F5 X03	F5 X02	F5 X01	F5 X00	

- Y-axis Coordinate of Finger 5 (**LSB 4 bits of Byte20 and 8 bits of Byte22**):
 - (a) Total 12 Bits format
 - (b) Y5-axis Coordinate Format

Table 4-14 LSB 4 Bits of Byte20 and 8 Bits of Byte22

MSB												LSB
F5 Y11	F5 Y10	F5 Y09	F5 Y08	F5 Y07	F5 Y06	F5 Y05	F5 Y04	F5 Y03	F5 Y02	F5 Y01	F5 Y00	

- X-axis Coordinate of Finger 6 (**MSB 4 bits of Byte24 and 8 bits of Byte25**):
 - (a) Total 12 Bits format
 - (b) X5-axis Coordinate Format

Table 4-15 MSB 4 Bits of Byte24 and 8 Bits of Byte25

MSB												LSB
F6 X11	F6 X10	F6 X09	F6 X08	F6 X07	F6 X06	F6 X05	F6 X04	F6 X03	F6 X02	F6 X01	F6 X00	

- Y-axis Coordinate of Finger 6 (**LSB 4 bits of Byte24 and 8 bits of Byte26**):
 - (a) Total 12 Bits format
 - (b) Y5-axis Coordinate Format

Table 4-16 LSB 4 Bits of Byte24 and 8 Bits of Byte26

	Title	ZET6223 Product Specification	Date Originated: 29-Jun-12
			Revision: 1.0
ZEITEC Semiconductor	Doc #: ZP-HW-PS-0007	Date Revised: 1-Oct-12	

MSB											LSB
F6 Y11	F6 Y10	F6 Y09	F6 Y08	F6 Y07	F6 Y06	F6 Y05	F6 Y04	F6 Y03	F6 Y02	F6 Y01	F6 Y00

- X-axis Coordinate of Finger 7 (**MSB 4 bits of Byte28 and 8 bits of Byte29**):
 - (a) Total 12 Bits format
 - (b) X5-axis Coordinate Format

Table 4-17 MSB 4 Bits of Byte28 and 8 Bits of Byte29

MSB											LSB
F7 X11	F7 X10	F7 X09	F7 X08	F7 X07	F7 X06	F7 X05	F7 X04	F7 X03	F7 X02	F7 X01	F7 X00

- Y-axis Coordinate of Finger 7 (**LSB 4 bits of Byte28 and 8 bits of Byte30**):
 - (a) Total 12 Bits format
 - (b) Y5-axis Coordinate Format

Table 4-18 LSB 4 Bits of Byte28 and 8 Bits of Byte30

MSB											LSB
F7 Y11	F7 Y10	F7 Y09	F7 Y08	F7 Y07	F7 Y06	F7 Y05	F7 Y04	F7 Y03	F7 Y02	F7 Y01	F7 Y00

- X-axis Coordinate of Finger 8 (**MSB 4 bits of Byte32 and 8 bits of Byte33**):
 - (a) Total 12 Bits format
 - (b) X5-axis Coordinate Format

Table 4-19 MSB 4 Bits of Byte32 and 8 Bits of Byte33

MSB											LSB
F8 X11	F8 X10	F8 X09	F8 X08	F8 X07	F8 X06	F8 X05	F8 X04	F8 X03	F8 X02	F8 X01	F8 X00

- Y-axis Coordinate of Finger 8 (**LSB 4 bits of Byte32 and 8 bits of Byte34**):
 - (a) Total 12 Bits format
 - (b) Y5-axis Coordinate Format

Table 4-20 LSB 4 Bits of Byte32 and 8 Bits of Byte34

MSB											LSB
F8 Y11	F8 Y10	F8 Y09	F8 Y08	F8 Y07	F8 Y06	F8 Y05	F8 Y04	F8 Y03	F8 Y02	F8 Y01	F8 Y00

- X-axis Coordinate of Finger 9 (**MSB 4 bits of Byte36 and 8 bits of Byte37**):
 - (a) Total 12 Bits format
 - (b) X5-axis Coordinate Format

	Title	ZET6223 Product Specification	Date Originated: 29-Jun-12
			Revision: 1.0
ZEITEC Semiconductor	Doc #: ZP-HW-PS-0007	Date Revised: 1-Oct-12	

Table 4-21 MSB 4 Bits of Byte36 and 8 Bits of Byte37

MSB											LSB
F9 X11	F9 X10	F9 X09	F9 X08	F9 X07	F9 X06	F9 X05	F9 X04	F9 X03	F9 X02	F9 X01	F9 X00

- Y-axis Coordinate of Finger 9 (**LSB 4 bits of Byte36 and 8 bits of Byte38**):
 - (a) Total 12 Bits format
 - (b) Y5-axis Coordinate Format

Table 4-22 LSB 4 Bits of Byte36 and 8 Bits of Byte38

MSB											LSB
F9 Y11	F9 Y10	F9 Y09	F9 Y08	F9 Y07	F9 Y06	F9 Y05	F9 Y04	F9 Y03	F9 Y02	F9 Y01	F9 Y00

- X-axis Coordinate of Finger 10 (**MSB 4 bits of Byte40 and 8 bits of Byte41**):
 - (a) Total 12 Bits format
 - (b) X5-axis Coordinate Format

Table 4-23 MSB 4 Bits of Byte40 and 8 Bits of Byte41

MSB											LSB
F10 X11	F10 X10	F10 X09	F10 X08	F10 X07	F10 X06	F10 X05	F10 X04	F10 X03	F10 X02	F10 X01	F10 X00

- Y-axis Coordinate of Finger 10 (**LSB 4 bits of Byte40 and 8 bits of Byte42**):
 - (a) Total 12 Bits format
 - (b) Y5-axis Coordinate Format

Table 4-24 LSB 4 Bits of Byte40 and 8 Bits of Byte42

MSB											LSB
F10 Y11	F10 Y10	F10 Y09	F10 Y08	F10 Y07	F10 Y06	F10 Y05	F10 Y04	F10 Y03	F10 Y02	F10 Y01	F10 Y00

- Key Byte (**Byte44 of TX Data**):
 - (a) Total 8 Bits format
 - (b) KX_EN = 1 : The Key X is active.

Table 4-25 Byte 44 of TX Data

MSB							LSB
K1_EN	K7_EN	K6_EN	K5_EN	K4_EN	K3_EN	K2_EN	K1_EN

	Title	ZET6223 Product Specification	Date Originated: 29-Jun-12
			Revision: 1.0
ZEITEC Semiconductor	Doc #:	ZP-HW-PS-0007	Date Revised: 1-Oct-12

- Z-Domain Byte (**Byte 7/11/15/19/23/27/31/35/39/43**)
 - (a) Total 5 Bits format
 - (b) There are 32-Step information to represent the Press Strength of Finger X, if touch panel with Heavy Press, the value of Z-Domain will be larger.

Table 4-26 Byte 7/11/15/19/23/27/31/35/39/43 of TX Data

MSB							LSB
0	0	0	FX_Z04	FX_Z03	FX_Z02	FX_Z01	FX_Z00

4.4.2 Reference C Program

```

BYTE InBuff [1024];

//receive coordinate report
void receiveData ( int FingerNum , int KeyNum , unsigned long x[] ,
unsigned long y[] , unsigned long z[] , u16 &fingers ,u8 &keys ) {
    int bufLength;

    if(KeyNum=0)
        bufLength = 3+4*FingerNum;
    else
        bufLength = 3+4*FingerNum+1;

    i2c_Read(InBuff, bufLength);

    if (InBuff[0] == 0x3c)
    {
        fingers = 0x0;
        // lnBuff[1]~lnBuff[2] = finger status
        fingers = fingers | (InBuff[1] << 8) | InBuff[2];

        for(int i=0;i<FingerNum;i++)
        {
            x[i]=(BYTE)((InBuff[3+4*i])>>4)*256 +
            (BYTE)InBuff[(3+4*i)+1];
            y[i]=(BYTE)((InBuff[3+4*i] & 0x0f)*256 +
            (BYTE)InBuff[(3+4*i)+2]);
            z[i]=(BYTE)((InBuff[(3+4*i)+3]) & 0x0f);
        }

        //if key enable
        if(KeyNum > 0)
            *keys = InBuff[3+4*FingerNum];
    }
}

```

4.5 TP Command

Table 4-27 Supported TP Command Type

	Title	ZET6223 Product Specification	Date Originated: 29-Jun-12 Revision: 1.0
	ZEITEC Semiconductor	Doc #: ZP-HW-PS-0007	Date Revised: 1-Oct-12

TP Command	Instruction	Byte Number	Description
Reset Mode	0xB0	1	Software Reset TP
Deep Sleep Mode	0xB1	1	Let TP enter Deep Sleep Mode
Dynamic Coordinate TX Mode	0xB2	1	After Host send this command, TP will give 17 bytes response that has Finger Application information
Idle Mode	0xB3	1	Let TP enter Idle Mode
Wake-Up Mode	0xB4	1	Wake TP Up from Deep Sleep Mode
Enable Charger Mode	0xB5	1	Let TP enter Charger Mode for Charger Noise Immunity
Disable Charger Mode	0xB6	1	Let TP disable from Charger Mode
Boot Loader Mode	0xB9	1	TP Enter Writer Mode

- **Reset Mode:**
Host can send the Reset Command (0xB0) to Reset TP.
- **Deep Sleep Mode :**
Host can send the Deep Sleep Command (0xB1) to reduce power consumption, when TP enter Deep Sleep Mode, the Power Consumption will be about 35uA. TP can be waked up by sending Wake-Up Command (0xB4).
- **Dynamic Coordinate TX Mode :**
When TP power on, the host needs to send the Dynamic Coordinate TX Command (0xB2) to get the Finger Application information, the information shows supported finger number, resolution, data format and traces number etc. After Host sent the command, TP will provide 17 bytes Finger Application response to Host.

After TP receives the command, TP will output the 17-Byte Finger Application information to Host device, content of the bytes are

1. Project Code(8 Bytes) => 1st byte ~ 8th byte
2. Resolution X(2 Bytes): Low Byte : 9th byte, High Byte : 10th byte => 9th byte ~ 10th byte
3. Resolution Y(2 Bytes): Low Byte : 11th byte, High Byte : 12th byte => 11th byte ~ 12th byte
4. Data Format(1 Byte): 0x40: Coordinate => 13th byte
5. X Trace Num(1 Byte): Trace Number of X-axis => 14th byte
6. Y Trace Num(1 Byte): Trace Number of Y-axis => 15th byte
7. Dynamic Finger(1 Byte): LSB 7-Bit : Finger Number, MSB : Key Enable(1'b1) / Key Disable(1'b0)
8. Reserve Byte(1Byte)

- **Idle Mode :**
Host can send the Idle Command (0xB3) to reduce power consumption, when TP enter Idle Mode, the Power Consumption will be about 140uA. Host can wake TP up by pull low INT Signal or send the Wake-Up Mode command.
- **Wake-Up Mode :**
The Command (0xB4) will wake TP up from Deep Sleep Mode.
- **Charger Mode :**

	Title	ZET6223 Product Specification	Date Originated: 29-Jun-12
			Revision: 1.0
ZEITEC Semiconductor	Doc #:	ZP-HW-PS-0007	Date Revised: 1-Oct-12

Charger Noise will affect the TP performance. The Charger Mode Command (0xB5) will let TP get Charger Noise Immunity ability.

- Discharger Mode :
Disable the Charger Mode.
- Boot Loader Mode :
TP will enter Writer Mode after receiving the Command(0xB9), Driver can update Flash ROM, Fig.4-10 shows the Boot Loader Flow.

4.5.1 Reference C Program

```

/*****
 [CMD instruction] 0xB0: Reset Mode
 [function]:
     callback: Software Reset TP;
 [parameters]:
     client[in]:  struct i2c_client - represent an I2C slave
 device;

 [return]:
     1;
 *****/
u8 zet6221_ts_reset_mode(struct i2c_client *client)
{
    u8 ts_reset_cmd[1] = {0xB0};

    int ret;

    ret=zet6223_i2c_write_tsdata(client, ts_reset_cmd, 1);

    return 1;
}

/*****
 [CMD instruction] 0xB1: Deep Sleep Mode
 [function]:
     callback: Let TP enter Deep Sleep Mode;
 [parameters]:
     client[in]:  struct i2c_client - represent an I2C slave
 device;

 [return]:
     1;
 *****/
u8 zet6223_ts_reset_mode(struct i2c_client *client)
{
    u8 ts_sleep_cmd[1] = {0xB1};

    int ret;

    ret=zet6223_i2c_write_tsdata(client, ts_sleep_cmd, 1);

    return 1;
}

/*****
 [CMD instruction] 0xB2: Dynamic Coordinate TX Mode

```

	Title	ZET6223 Product Specification	Date Originated: 29-Jun-12
			Revision: 1.0
ZEITEC Semiconductor	Doc #:	ZP-HW-PS-0007	Date Revised: 1-Oct-12

```

[function]:
    callback: get dynamic report information;
[parameters]:
    client[in]:  struct i2c_client - represent an I2C slave
device;

[return]:
    1;
*****/
u8 zet6223_ts_get_report_mode(struct i2c_client *client)
{
    u8 ts_report_cmd[1] = {0xB2};
    u8 ts_reset_cmd[1] = {0xB0};
    u8 ts_in_data[17] = {0,0,0,0,0,0,0,0,0,0,0,0,0,0,0,0,0};

    u8 pc[8];
    int ResolutionX, ResolutionY, FingerNum, KeyNum;

    int ret;

    ret=zet6223_i2c_write_tsdata(client, ts_report_cmd, 1);

    if (ret > 0)
    {
        while(1)
        {
            udelay(1);

            if (gpio_get_value(S3C64XX_GPN(9)) == 0)
            {
                ret=zet6223_i2c_read_tsdata(client, ts_in_data, 17);

                for(i=0;i<8;i++)
                {
                    pc[i]=ts_in_data[i] & 0xff;
                }
                ResolutionX = ts_in_data[9] & 0xff;
                ResolutionX = (ResolutionX << 8)|(ts_in_data[8] & 0xff);
                ResolutionY = ts_in_data[11] & 0xff;
                ResolutionY = (ResolutionY << 8) | (ts_in_data[10] & 0xff);
                FingerNum = (ts_in_data[15] & 0x7f);
                KeyNum = (ts_in_data[15] & 0x80);

                if(KeyNum==0)
                    bufLength = 3+4*FingerNum;
                else
                    bufLength = 3+4*FingerNum+1;

                break;
            }
        }
    }
    return 1;
}
/*****

```

	Title	ZET6223 Product Specification	Date Originated: 29-Jun-12
			Revision: 1.0
ZEITEC Semiconductor	Doc #:	ZP-HW-PS-0007	Date Revised: 1-Oct-12

```

[CMD instruction] 0xB3: Idle Mode
[function]:
    callback: Let TP enter Idle Mode;
[parameters]:
    client[in]:  struct i2c_client - represent an I2C slave
device;

[return]:
    1;
*****/
u8 zet6223_ts_idle_mode(struct i2c_client *client)
{
    u8 ts_idle_cmd[1] = {0xB3};

    int ret;

    ret=zet6223_i2c_write_tsdata(client, ts_idle_cmd, 1);

    return 1;
}

/*****/
[CMD instruction] 0xB4: Wake-Up Mode
[function]:
    callback: Wake TP Up from Deep Sleep Mode;
[parameters]:
    client[in]:  struct i2c_client - represent an I2C slave
device;

[return]:
    1;
*****/
u8 zet6223_ts_wakeup_mode(struct i2c_client *client)
{
    u8 ts_wakeup_cmd[1] = {0xB4};

    int ret;

    ret=zet6223_i2c_write_tsdata(client, ts_wakeup_cmd, 1);

    return 1;
}

/*****/
[CMD instruction] 0xB5: Enable Charger Mode
[function]:
    callback: Let TP enter Charger Mode for Charger Noise Immunity;
[parameters]:
    client[in]:  struct i2c_client - represent an I2C slave
device;

[return]:
    1;
*****/
u8 zet6223_ts_charger_mode(struct i2c_client *client)
{
    u8 ts_charger_cmd[1] = {0xB5};

```

	Title	ZET6223 Product Specification	Date Originated: 29-Jun-12
			Revision: 1.0
ZEITEC Semiconductor	Doc #:	ZP-HW-PS-0007	Date Revised: 1-Oct-12

```

int ret;

ret=zet6223_i2c_write_tsdata(client, ts_charger_cmd, 1);

return 1;
}

/*****
[CMD instruction] 0xB6: Disable Charger Mode
[function]:
    callback: Let TP disable from Charger Mode;
[parameters]:
    client[in]: struct i2c_client - represent an I2C slave
device;

[return]:
    1;
*****/
u8 zet6223_ts_noncharger_mode(struct i2c_client *client)
{
    u8 ts_noncharger_cmd[1] = {0xB6};

    int ret;

    ret=zet6223_i2c_write_tsdata(client, ts_noncharger_cmd, 1);

    return 1;
}

/*****
[CMD instruction] 0xB9: Enter Writer Mode
[function]:
    callback: To enter writer mode to update firmware;
[parameters]:
    client[in]: struct i2c_client - represent an I2C slave
device;

[return]:
    1;
*****/
u8 zet6223_ts_writer_mode(struct i2c_client *client)
{
    u8 ts_writer_cmd[1] = {0xB9};

    int ret;

    ret=zet6223_i2c_write_tsdata(client, ts_writer_cmd, 1);

    return 1;
}

```

	Title	ZET6223 Product Specification	Date Originated: 29-Jun-12 Revision: 1.0
	ZEITEC Semiconductor	Doc #: ZP-HW-PS-0007	Date Revised: 1-Oct-12

4.6 Boot Loader Workflow

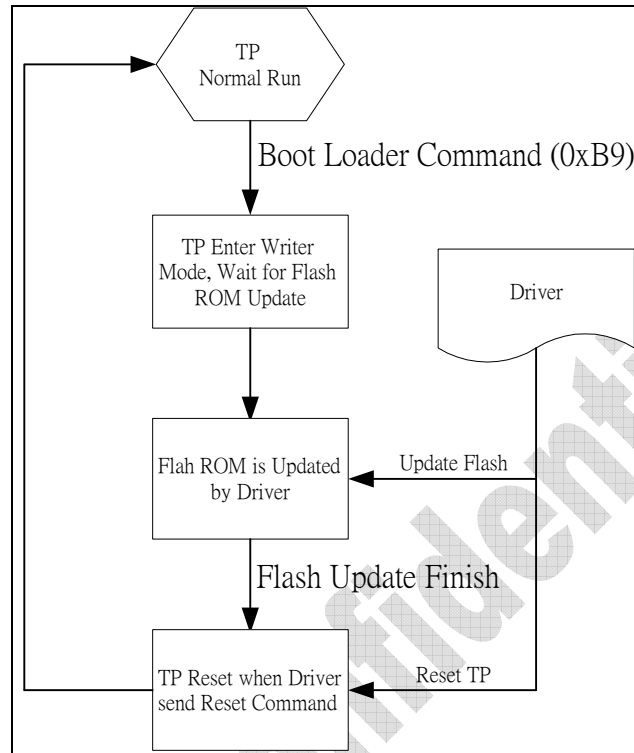

Figure 4-18 Boot Loader Flow

4.6.1 Reference C Program

```

#include "zet6223_fw.h"

static unsigned char zeitec_zet6223_page[130] __initdata;

u8 zet6221_ts_sndpwd(struct i2c_client *client)
{
    u8 ts_sndpwd_cmd[3] = {0x20,0xC5,0x9D};

    int ret;

    ret=zet6223_i2c_write_tsdata(client, ts_sndpwd_cmd, 3);

    return 1;
}

u8 zet6223_ts_sfr(struct i2c_client *client)
{
    u8 ts_cmd[1] = {0x2C};
    u8 ts_in_data[16] = {0,0,0,0,0,0,0,0,0,0,0,0,0,0,0,0};
    u8 ts_cmd17[17] = {0,0,0,0,0,0,0,0,0,0,0,0,0,0,0,0,0};
    int ret;
    int i;

    ret=zet6223_i2c_write_tsdata(client, ts_cmd, 1);
  
```

	Title	ZET6223 Product Specification	Date Originated: 29-Jun-12
			Revision: 1.0
ZEITEC Semiconductor	Doc #: ZP-HW-PS-0007		Date Revised: 1-Oct-12

```

ret=zet6223_i2c_read_tsdata(client, ts_in_data, 16);
msleep(100);

for(i=0;i<16;i++)
{
    ts_cmd17[i+1]=ts_in_data[i];
}

if(ts_in_data[14]==0x3D)
{
    ts_cmd[0]=0x2D;
    ret=zet6223_i2c_write_tsdata(client, ts_cmd, 1);
    msleep(500);

    ts_cmd17[15]=0x7D;
    ts_cmd17[0]=0x2E;
    ret=zet6223_i2c_write_tsdata(client, ts_cmd17, 17);

}else
{
    ts_cmd17[15]=0x3D;
    ts_cmd17[0]=0x2B;
    ret=zet6223_i2c_write_tsdata(client, ts_cmd17, 17);
}

return 1;
}

u8 zet6221_ts_masserase(struct i2c_client *client)
{
    u8 ts_cmd[1] = {0x24};

    int ret;

    ret=zet6223_i2c_write_tsdata(client, ts_cmd, 1);

    return 1;
}

u8 zet6223_ts_resetmcu(struct i2c_client *client)
{
    u8 ts_cmd[1] = {0x29};

    int ret;

    ret=zet6223_i2c_write_tsdata(client, ts_cmd, 1);

    return 1;
}

u8 zet6223_ts_hwcmd(struct i2c_client *client)
{
    u8 ts_cmd[1] = {0xB9};

    int ret;

    ret=zet6223_i2c_write_tsdata(client, ts_cmd, 1);

```

	Title	ZET6223 Product Specification	Date Originated: 29-Jun-12
			Revision: 1.0
ZEITEC Semiconductor	Doc #:	ZP-HW-PS-0007	Date Revised: 1-Oct-12

```

return 1;
}

int __init zet6223_downloader( struct i2c_client *client,
unsigned short ver, unsigned char * data )
{
    int BufLen=0;
    int BufPage=0;
    int BufIndex=0;
    int ret;
    int i;

#if defined(RSTPIN_ENABLE)
    msleep(5);
    gpio_direction_output(TS_RST_GPIO, 0);
    msleep(5);
    gpio_set_value(TS_RST_GPIO,GPIO_LOW);

    msleep(200);
#else
    zet6223_ts_hwcmd(client);
    msleep(200);
#endif

    //send password
    zet6223_ts_sndpwd(client);
    msleep(200);

    //sfr
    zet6223_ts_sfr(client);
    msleep(200);

    //mass erase
    zet6223_ts_masserase(client);
    msleep(200);

    BufLen=sizeof(zeitec_zet6223_firmware)/sizeof(char);

    while(BufLen>0)
    {
        memset(zeitec_zet6223_page,0x00,130);
        if(BufLen>128)
        {
            for(i=0;i<128;i++)
            {
                zeitec_zet6223_page[i+2]=zeitec_zet6221_firmware[BufIndex];
                BufIndex+=1;
            }
            zeitec_zet6223_page[0]=0x22;
            zeitec_zet6223_page[1]=BufPage;
            BufLen-=128;
        }
        else
        {
            for(i=0;i<BufLen;i++)
            {

```

	Title	ZET6223 Product Specification	Date Originated: 29-Jun-12
			Revision: 1.0
ZEITEC Semiconductor	Doc #:	ZP-HW-PS-0007	Date Revised: 1-Oct-12

```

zeitec_zet6223_page[i+2]=zeitec_zet6223_firmware[BufIndex];
    BufIndex+=1;
}
zeitec_zet6223_page[0]=0x22;
zeitec_zet6223_page[1]=BufPage;
BufLen=0;
}
ret=zet6223_i2c_write_tsdata(client,      zeitec_zet6223_page,
130);
msleep(200);
BufPage+=1;
}

#if defined(RSTPIN_ENABLE)
    gpio_set_value(TS_RST_GPIO,GPIO_HIGH);
    msleep(200);
#endif

zet6221_ts_resetmcu(client);
msleep(100);
}

```

ZEITEC Confidential

	Title ZET6223 Product Specification	Date Originated: 29-Jun-12
		Revision: 1.0
ZEITEC Semiconductor	Doc #: ZP-HW-PS-0007	Date Revised: 1-Oct-12

5 AC CHARACTERISITIC

5.1 I2C Slave Mode Communication Timing

Figure 5-1 shows the timing condition of the I2C interface. The characteristics of I2C interface are given in Figure 5-1. The Touch Panel adopts a bit rate of up to 400 Kbits/sec in Fast mode. The Touch Panel is defined as I2C slave mode interface. The Host generates the clock signal through the serial clock (SCL) pin and data are transferred and received through the serial data (SDA) pin. Clock synchronization should be enabled.

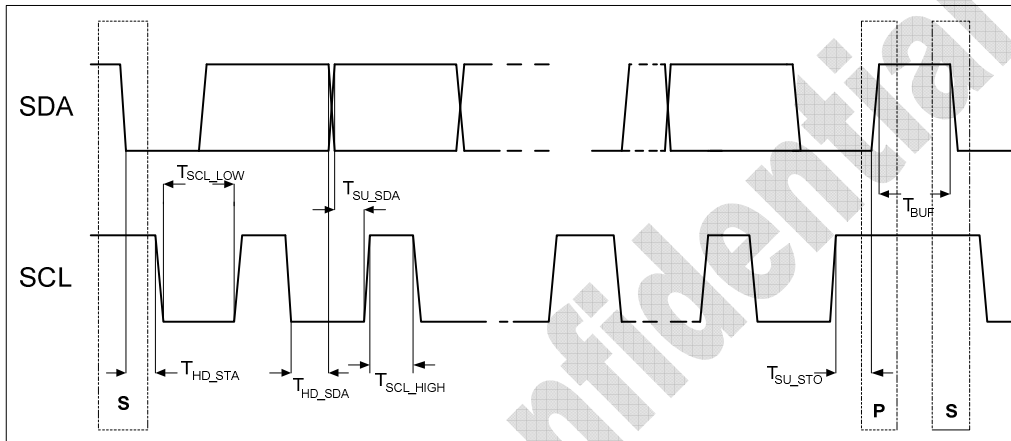



Figure 5-1 I2C Interface Timing

Table 5-1 Characteristics of the SDA and SCL Pins for I2C Interface

Symbol	Parameter	Standard Mode		Fast Mode		Unit
		Min.	Max.	Min.	Max.	
F_{SCL}	Frequency of SCL signal	0	100	0	400	kHz
T_{HD_STA}	Hold time (repeated) Start condition. After this period, the first clock pulse is generated.	4.0	–	1.2	–	μ s
T_{SCL_LOW}	Low-State Period of SCL signal	5.3	–	1.5	–	μ s
T_{SCL_HIGH}	High-State Period of SCL signal	2.7	–	0.8	–	μ s
T_{HD_SDA}	Data Hold time	2.7	–	0.8	–	μ s
T_{SU_SDA}	Data Set-Up time	2.7	–	0.8	–	us
T_{SU_STO}	Set-Up time for Stop condition	3.6	–	1.0	–	μ s
T_{BUF}	Bus free time between a Stop and Start condition	30	–	30	–	μ s

	Title	ZET6223 Product Specification	Date Originated: 29-Jun-12
			Revision: 1.0
ZEITEC Semiconductor	Doc #: ZP-HW-PS-0007		Date Revised: 1-Oct-12

5.2 RC and Reset Timing

Table 5-2 IRC and Reset Timing

Symbol	Description	Min	Typ	Max	Unit
$T_{PowerOn}$	Power-on Slope Require (DVDD 0V to 3V)	0.05	–	2	ms
T_{Init}	Power-on to Touch Available	–	–	30	ms

The input power must be a smooth and continuous ramp from 10% to 90% of 3V.

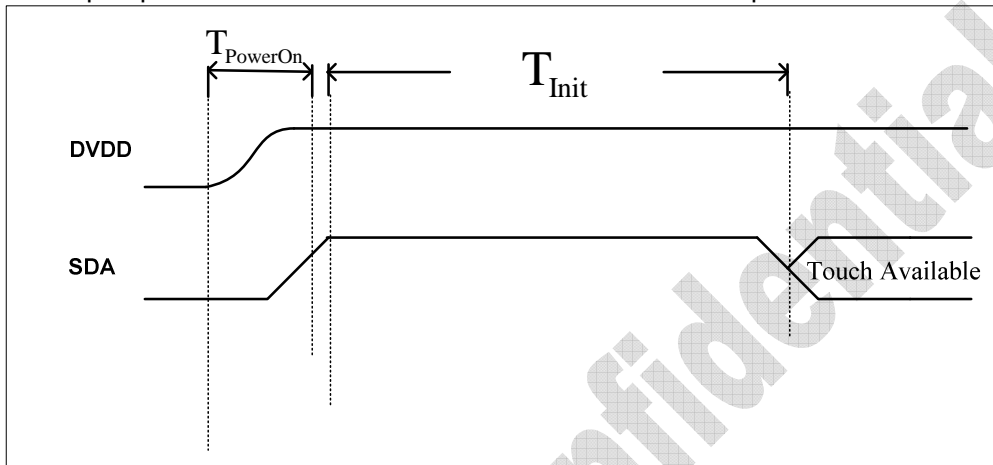



Figure 5-2 IRC Power-on Initialization Timing

	Title	ZET6223 Product Specification	Date Originated: 29-Jun-12
			Revision: 1.0
ZEITEC Semiconductor	Doc #:	ZP-HW-PS-0007	Date Revised: 1-Oct-12

6 DC CHARACTERISTICS

This section presents the DC electrical specifications of ZET6223 device. Specification is valid for -20°C to 85°C as specified.

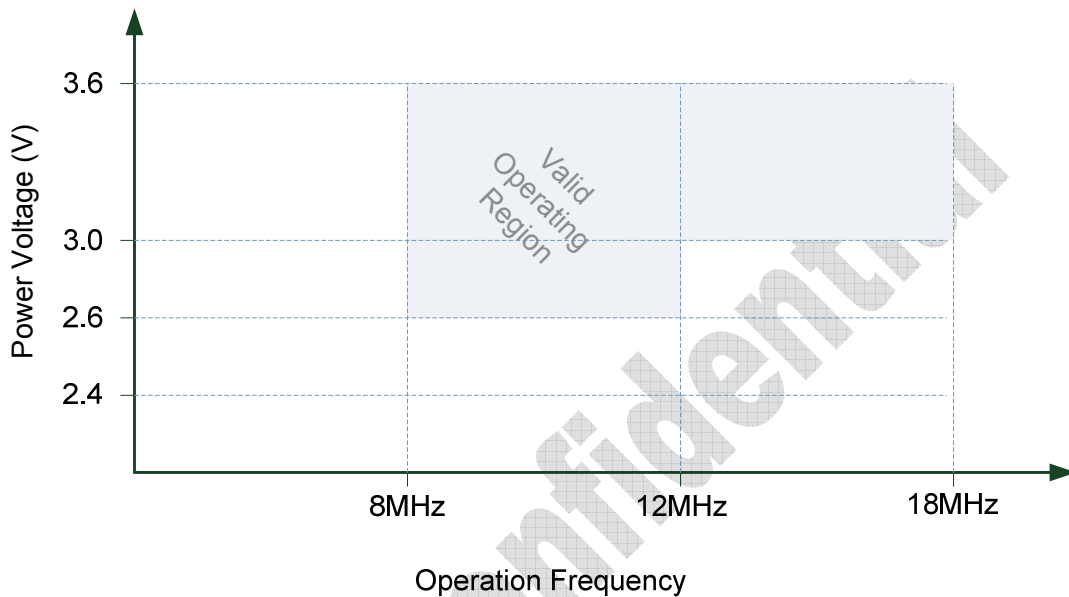



Figure 6-1 Valid Operating Region

Table 6-1 Unit of Measure

Symbol	Unit of Measure	Symbol	Unit of Measure
°C	Degree Celsius	ms	Mill second
dB	Decibels	mV	Mill volts
fF	Femto farad	nA	Nan ampere
Hz	Hertz	ns	Nanosecond
MHz	Megahertz	nV	Nan volts
μA	Microampere	Ω	Ohm
μF	Microfarad	pA	Pico ampere
μS	Microsecond	pF	Pico farad
μV	Microvolt	V	Volts
μW	Microwatts	σ	Sigma : One Standard Deviation
mA	Mill ampere	ps	Pico second

	Title	ZET6223 Product Specification	Date Originated: 29-Jun-12
			Revision: 1.0
ZEITEC Semiconductor	Doc #: ZP-HW-PS-0007	Date Revised: 1-Oct-12	

6.1 Absolute Maximum Ratings

Table 6-2 Absolute Maximum Ratings

Sym.	Parameter	Min.	Typ.	Max.	Units	Notes
T _{STG}	Storage Temperature	-55	25	+100	°C	
T _A	Ambient Temperature with Power Applied	-20	—	+85	°C	
V _{DD33}	Supply Voltage on VDD33 Relative to VSS	-0.3	—	+3.6	V	
V _{DDIO}	Supply Voltage on VDDIO Relative to VSS	-0.3	—	+3.6	V	
V _{IO}	DC Input Voltage	V _{SS} -0.3	—	V _{SS} +0.3	V	
V _{IOZ}	DC Voltage Applied to Tri-state	V _{SS} -0.3	—	V _{SS} +0.3	V	
I _{MIO}	Maximum Current into any Port Pin	-15	—	+30	mA	
ESD	Electrostatic Discharge Voltage	—	—	2000	V	Human Body Model ESD
LU	Latch-up Current	—	—	200	mA	

	Title	ZET6223 Product Specification	Date Originated: 29-Jun-12 Revision: 1.0
	ZEITEC Semiconductor	Doc #: ZP-HW-PS-0007	Date Revised: 1-Oct-12

6.2 DC Electrical Characteristics

Table 6-3 DC Specifications

T_A = 25°C

Sym.	Parameter	Min.	Typ.	Max.	Units	Condition
VDD33	Supply Voltage for Digital Circuit	2.6	—	3.6	V	VDD33=VDDIO
VDDIO	Supply Voltage for Digital I/O Pad	2.6	—	3.6	V	VDD33=VDDIO
VDDIO	Supply Voltage for Digital I/O Pad	1.65	—	3.6	V	VDD33>VDDIO
AVDD33	Supply Voltage for Analog Circuit	2.6	—	3.6	V	
IDD	Supply Current	3	8	16	mA	Depend on Sensor Mode and Sensor Number
V _{OH33}	High Output Voltage for Digital I/O Pad	2.8			V	VDDIO=3.3V, I _{out} =2~8mA
V _{OL33}	Low Output Voltage for Digital I/O Pad			0.3	V	VDDIO=3.3V, I _{out} =2~8mA
V _{IH33}	High Level Input Voltage for Digital I/O Pad	2.0			V	VDDIO=3.3V
V _{IL33}	Low Level Input Voltage for Digital I/O Pad			0.9	V	VDDIO=3.3V
V _{OH18}	High Output Voltage for Digital I/O Pad	1.2			V	VDDIO=1.8V, I _{out} =1~4mA
V _{OL18}	Low Output Voltage for Digital I/O Pad			0.3	V	VDDIO=1.8V, I _{out} =1~4mA
V _{IH18}	High Level Input Voltage for Digital I/O Pad	1.3			V	VDDIO=1.8V
V _{IL18}	Low Level Input Voltage for Digital I/O Pad			0.5	V	VDDIO=1.8V

	Title ZET6223 Product Specification	Date Originated: 29-Jun-12
		Revision: 1.0
ZEITEC Semiconductor	Doc #: ZP-HW-PS-0007	Date Revised: 1-Oct-12

7 PACKAGE INFORMATION

7.1 68Pin, QFN 8mm X 8mm

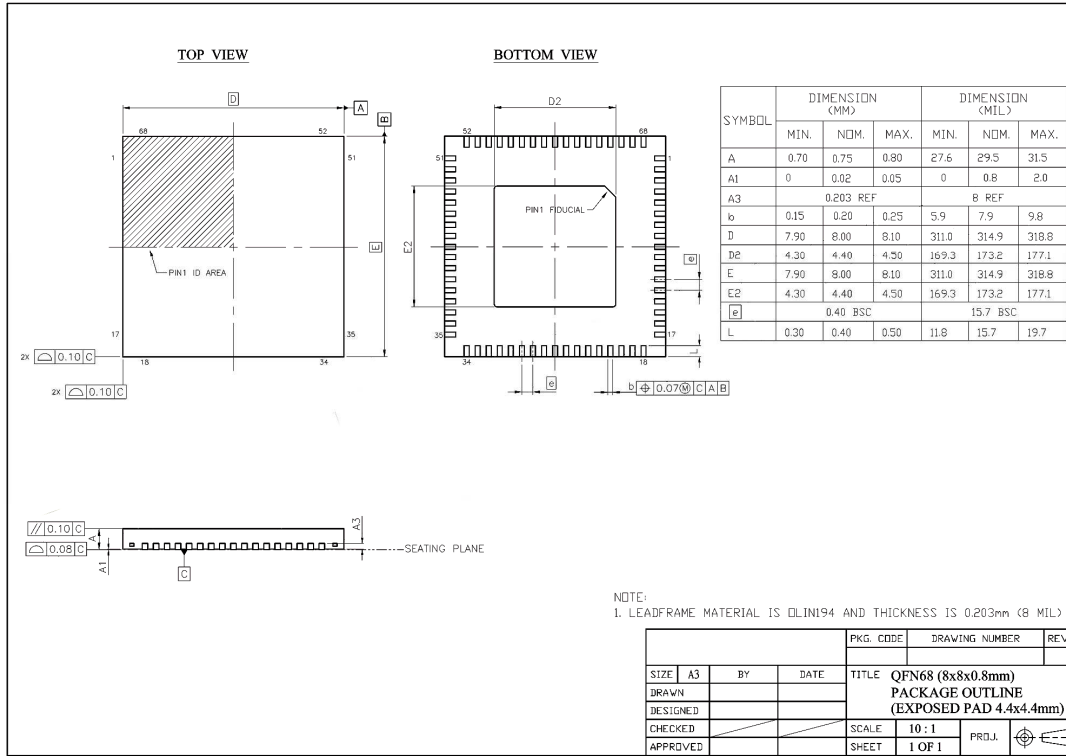



Figure 7-1 68-Pin, QFN 8mm X 8mm

	Title ZET6223 Product Specification	Date Originated: 29-Jun-12
		Revision: 1.0
ZEITEC Semiconductor	Doc #: ZP-HW-PS-0007	Date Revised: 1-Oct-12

7.2 48Pin, QFN 6mm X 6mm

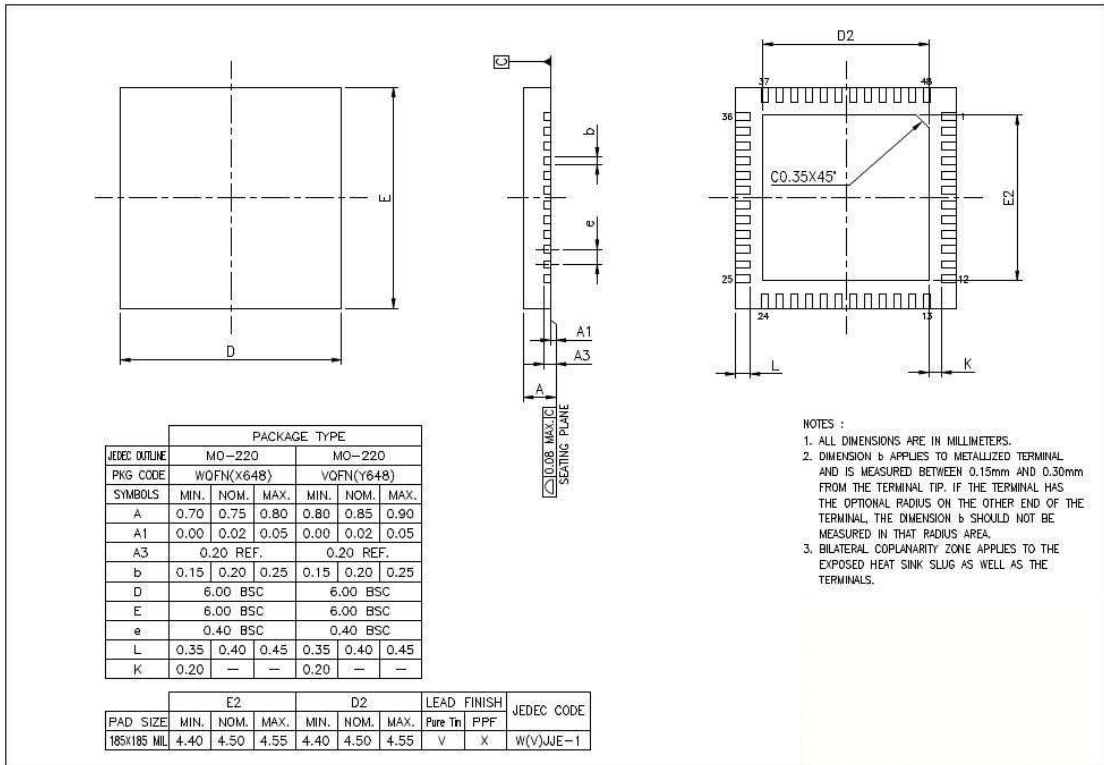



Figure 7-2 48Pin, QFN 6mm X 6mm

	Title	ZET6223 Product Specification	Date Originated: 29-Jun-12
			Revision: 1.0
ZEITEC Semiconductor	Doc #:	ZP-HW-PS-0007	Date Revised: 1-Oct-12

8 MARKING DEFINITION

8.1 Marking Information

Table 8-1 Ordering Information

Ordering Code	Package	Panel size (inch)	ITO Trace (I/O)
ZET6223WTA	QFN-68 (8mmX8mm, Pitch 0.4mm)	7"~11.6"	48 (TX:TRX:RX=16:2:30)
ZET6223WNA	QFN-48 (6mmX6mm, Pitch 0.4mm)	5"~8"	36 (TX:TRX:RX=14:2:20)

Example : Z E T 6 2 2 3 W T A 7 H 1 1 0 N 8 M 1 A T X X X

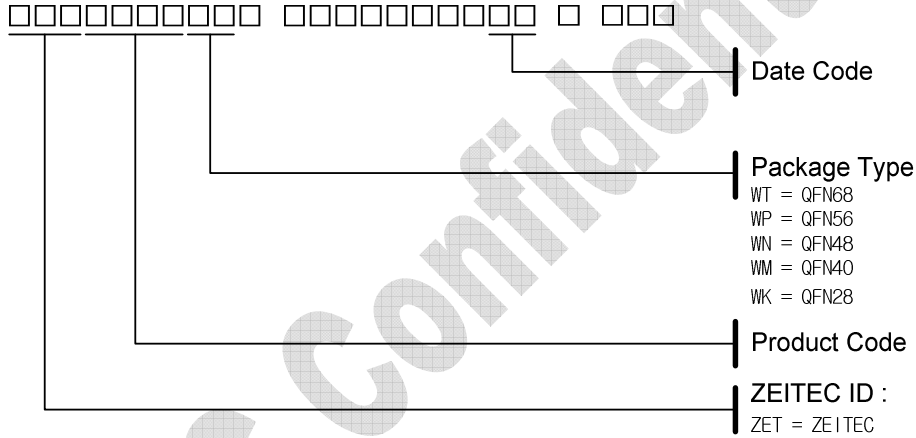



Figure 8-1 Ordering Code Definitions

	Title	ZET6223 Product Specification	Date Originated: 29-Jun-12
			Revision: 1.0
ZEITEC Semiconductor	Doc #: ZP-HW-PS-0007		Date Revised: 1-Oct-12

Headquarters

ZEITEC Semiconductor Co., LTD.
 3F., No.49, Jinshan 7th St., East Dist.,
 Hsinchu City 300, Taiwan (R.O.C.)
 Tel: +886 3 579 0045
 Fax: +886 3 579 9960

Product Contact

Web Site

<http://www.zeitecsemi.com>

Sales Contact

sales@zeitecsemi.com

IMPORTANT NOTICE

ZEITEC Semiconductor Co., LTD. The information contained herein is subject to change without notice. ZEITEC Semiconductor Co., LTD. assumes no responsibility for the use of any circuitry other than circuitry embodied in a ZEITEC product. Nor does it convey or imply any license under patent or other rights. ZEITEC products are not warranted nor intended to be used for medical, life support, life saving, critical control or safety applications, unless pursuant to an express written agreement with ZEITEC. Furthermore, ZEITEC does not authorize its products for use as critical components in life-support systems where a malfunction or failure may reasonably be expected to result in significant injury to the user. The inclusion of ZEITEC products in life-support systems application implies that the manufacturer assumes all risk of such use and in doing so indemnifies ZEITEC against all charges.

Any Source Code (software and/or firmware) is owned by ZEITEC Semiconductor Co., LTD. (ZEITEC). ZEITEC hereby grants to licensee a personal, non-exclusive, non-transferable license to copy, use, modify, create derivative works of, and compile the ZEITEC Source Code and derivative works for the sole purpose of creating custom software and or firmware in support of licensee product to be used only in conjunction with a ZEITEC integrated circuit as specified in the applicable agreement. Any reproduction, modification, translation, compilation, or representation of this Source Code except as specified above is prohibited without the express written permission of ZEITEC.

Disclaimer: ZEITEC MAKES NO WARRANTY OF ANY KIND, EXPRESS OR IMPLIED, WITH REGARD TO THIS MATERIAL, INCLUDING, BUT NOT LIMITED TO, THE IMPLIED WARRANTIES OF MERCHANTABILITY AND FITNESS FOR A PARTICULAR PURPOSE. ZEITEC reserves the right to make changes without further notice to the materials described herein. ZEITEC does not assume any liability arising out of the application or use of any product or circuit described herein. ZEITEC does not authorize its products for use as critical components in life-support systems where a malfunction or failure may reasonably be expected to result in significant injury to the user. The inclusion of ZEITEC product in a life-support systems application implies that the manufacturer assumes all risk of such use and in doing so indemnifies ZEITEC against all charges.